

STRATA PLAN OF LOT A, BLOCK
"A", D.L. 5316, PLAN 21526,
GROUP 1, N.W.D.

FIRST SHEET SHEET 1 OF 33 SHEETS

PHASE I

STRATA PLAN VR 2055

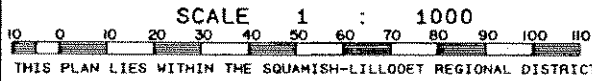

STRATA PLAN VR 2055
DEPOSITED AND REGISTERED IN THE LAND
TITLE OFFICE AT VANCOUVER, B.C.,
THIS 14 DAY OF January 1988.

THIS PLAN LIES WITHIN THE SQUAMISH-LILLOOET REGIONAL DISTRICT
RESORT MUNICIPALITY OF WHISTLER
THE ADDRESS FOR THE SERVICE OF DOCUMENTS
ON THE STRATA CORPORATION IS :-
THE OWNERS STRATA PLAN VR
C/O 2225 FOLKSTONE WAY
WEST VANCOUVER, B.C.
V7S 2Y6

Denny
REGISTRAR

R134323

CIVIC ADDRESS :- SNOWRIDGE CRESCENT
D.L. BLOCK C 7165
12 13 14 23

D.L. 4979
PLAN 19851
65

FORM 'E' OF R 134322

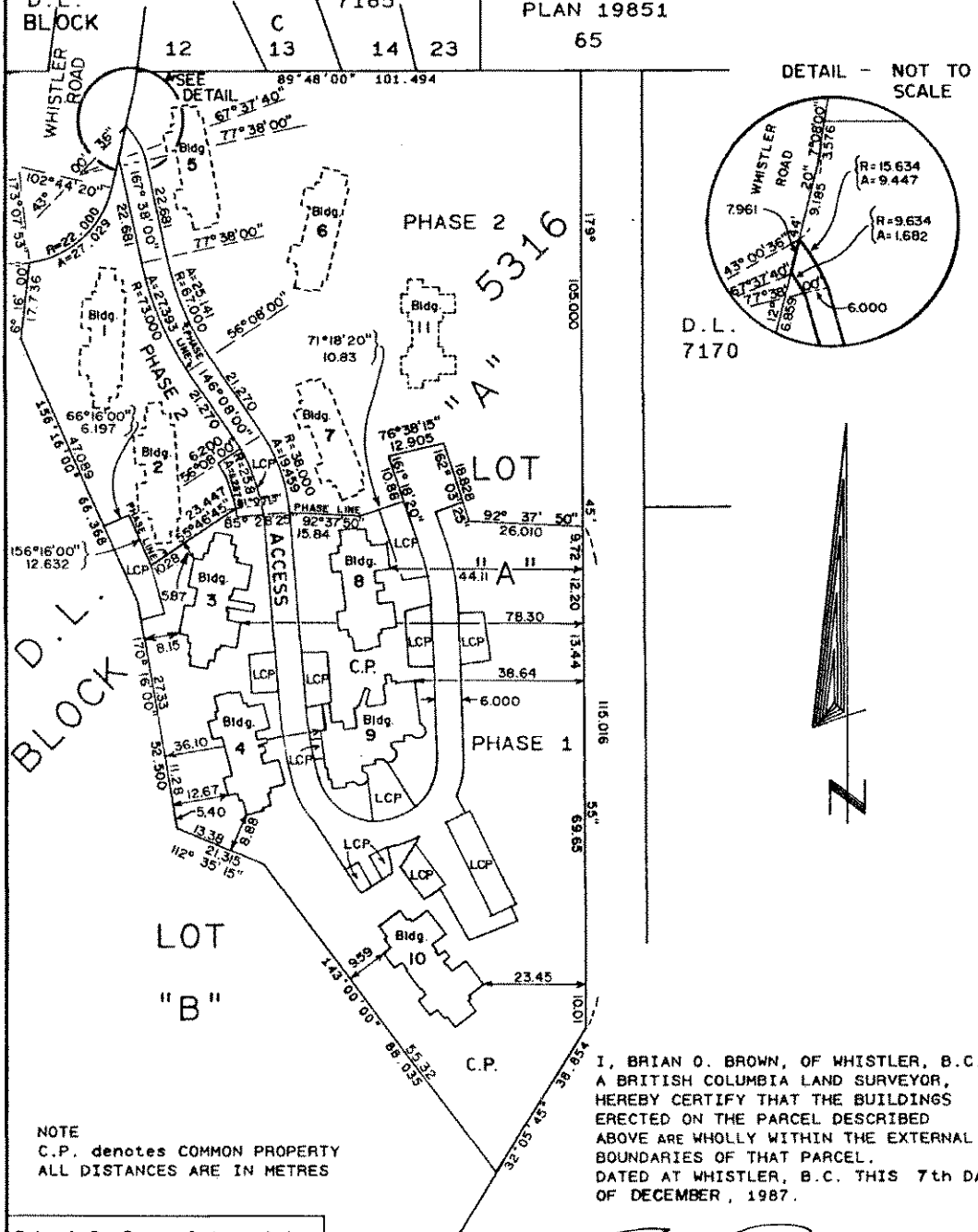

DETAIL - NOT TO SCALE

D.L. 7170

NOTE
C.P. denotes COMMON PROPERTY
ALL DISTANCES ARE IN METRES

I, BRIAN O. BROWN, OF WHISTLER, B.C.,
A BRITISH COLUMBIA LAND SURVEYOR,
HEREBY CERTIFY THAT THE BUILDINGS
ERECTED ON THE PARCEL DESCRIBED
ABOVE ARE WHOLLY WITHIN THE EXTERNAL
BOUNDARIES OF THAT PARCEL.
DATED AT WHISTLER, B.C. THIS 7th DAY
OF DECEMBER, 1987.

Robert B. Brown & Associates
Professional Land Surveyors
P.O. Box 13, Whistler, B.C.
V0N 1B0 932 - 5426

Brian Brown
B.C.L.S.

CONDOMINIUM ACT

PHASE I
STRATA PLAN VR 2055

LOT NO.	SHEET NO.	FORM 1	FORM 2	FORM 3
		SECTION 3(i)(f)	SECTION 3(i)(g)	SECTION 3(i)(h)
		SCHEDULE OF UNIT ENTITLEMENT	SCHEDULE OF INTEREST UPON DESTRUCTION	SCHEDULE OF VOTING RIGHTS
		UNIT ENTITLEMENT	INTEREST UPON DESTRUCTION	NUMBER OF VOTES
1	4 & 5	105	156	
2	4 & 5	107	143	
3	4 & 5	107	143	
4	4 & 5	106	156	
5	6 & 7	122	174	
6	6 & 7	122	174	
7	8	106	156	
8	9 & 10	122	193	
9	8	88	156	
10	9 & 10	122	199	
11	13 & 14	120	212	
12	12	105	193	
13	11	86	162	
14	13 & 14	120	212	
15	12	105	193	
16	11	86	156	
17	15, 16 & 17	134	237	
18	15, 16 & 17	135	237	
19	15, 16 & 17	139	243	
20	18	119	212	
21	19	118	218	
22	20 & 21	137	237	
23	18	118	212	
24	19	118	218	
25	20 & 21	137	237	
PHASE I AGGREGATE		2884	4829	

ACCEPTED AS TO FORMS
1, 2 & 3
THIS 24 DAY OF December 1987

[Signature]
SUPERINTENDENT OF REAL ESTATE

Robert B Brown & Associates
Professional Land Surveyors
Box 13 Whistler, B.C.
VON 1B0 932-5426

[Signature] B.C.L.S.
December 7, 1987.

FILED VAVAS2055 L22418 2003-10-16-11.54.16.480949

CONDOMINIUM ACT

PHASE I
STRATA PLAN VR 2055

STATUTORY DECLARATION

I, THE UNDERSIGNED, DO SOLEMNLY DECLARE THAT :-
(1) I, THE UNDERSIGNED, AM THE DULY AUTHORIZED AGENT OF THE OWNER DEVELOPER.
(2) THE STRATA PLAN IS ENTIRELY FOR RESIDENTIAL USE
I MAKE THIS SOLEMN DECLARATION CONSCIENTIOUSLY BELIEVING IT TO BE TRUE,
AND KNOWING THAT IT IS OF THE SAME FORCE AND EFFECT AS IF MADE UNDER OATH.

DECLARED BEFORE ME AT Vancouver
IN THE PROVINCE OF BRITISH COLUMBIA
THIS 10th DAY OF December, 1987.

R.W. Wolfe

Bernie Chan
COMMISSIONER FOR TAKING AFFIDAVITS WITHIN THE PROVINCE OF BRITISH COLUMBIA

SIGNATURES

OWNER

INTERNATIONAL LAND CORPORATION LTD.

[Signature]
AUTHORIZED SIGNATORY
R.W. Wolfe
AUTHORIZED SIGNATORY

APPROVED AS PHASE I OF A 2 PHASE STRATA PLAN UNDER THE "CONDOMINIUM ACT" THIS 10 DAY OF December, 1987.

[Signature]
APPROVING OFFICER - RESORT MUNICIPALITY OF WHISTLER

MORTGAGEE

THE TORONTO-DOMINION BANK
(By it's Attorney's in fact)
PLAN R307477

[Signature]
AUTHORIZED SIGNATORY
AUTHORIZED SIGNATORY

OPTION TO PURCHASE R41366

WHISTLER MOUNTAIN SKI CORPORATION

[Signature]
AUTHORIZED SIGNATORY
W. + Sweet
AUTHORIZED SIGNATORY

A. Santelmo
WITNESS AS TO BOTH SIGNATURES
Shirley Tautscher
700 W. Georgia St.
ADDRESS Vancouver, B.C.

Bank Officer
OCCUPATION

I, BRIAN O. BROWN OF THE MUNICIPALITY OF WHISTLER, BRITISH COLUMBIA LAND SURVEYOR, HEREBY CERTIFY THAT THE BUILDING SHOWN IN THIS STRATA PLAN HAS NOT, AS OF THE 7th DAY OF DECEMBER, 1987 BEEN PREVIOUSLY OCCUPIED. DATED AT WHISTLER, BRITISH COLUMBIA
THIS 7th DAY OF DECEMBER, 1987.

Brian Brown B.C.L.S.

[Signature] B.C.L.S.

December 7, 1987.

Robert B. Brown & Associates
Professional Land Surveyors
P.O. Box 13, Whistler, B.C.
V0N 1B0 932 - 5426

FILED 182418 2003-10-16-11:54:16.480949

VAVAS2055

FILED

12

PLAN OF STRATA LOTS 1, 2, 3 & 4

PHASE I

STRATA PLAN VR 2055

SCALE 1 : 125



BUILDING 3

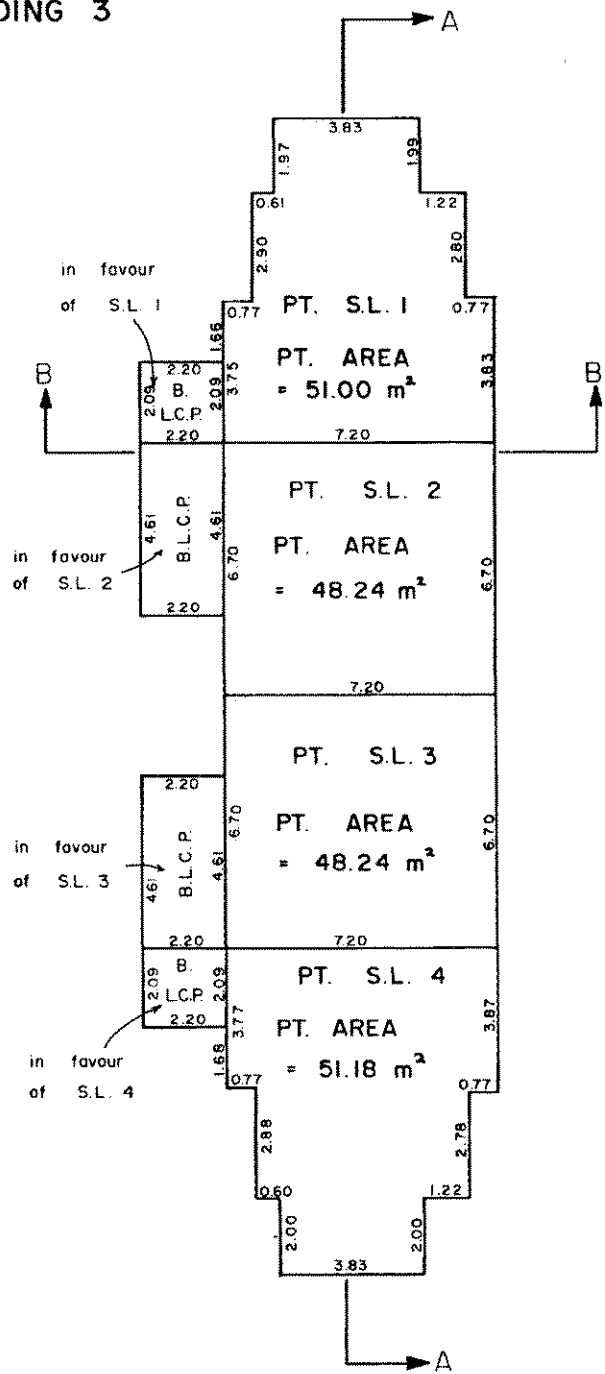

PLAN OF GROUND FLOOR

NOTE:
 S.L. DENOTES STRATA LOT
 C.P. DENOTES COMMON PROPERTY
 C.F. DENOTES COMMON FACILITY
 L.C.P. DENOTES LIMITED COMMON PROPERTY
 B. DENOTES BALCONY
 BALCONIES ARE COMMON PROPERTY AND ARE NOT INCLUDED IN SQUARE METRE (M²) AREAS
 ALL DISTANCES ARE IN METRES.

B.C.L.S.

December 7, 1987.

FILED 182418 2803-10-16-11.54.16.480949

VAVAS2055

FILED

PLAN OF STRATA LOTS 1,2,3 & 4

PHASE I

STRATA PLAN VR 2055

SCALE 1 : 125

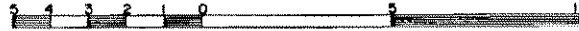

BUILDING 3

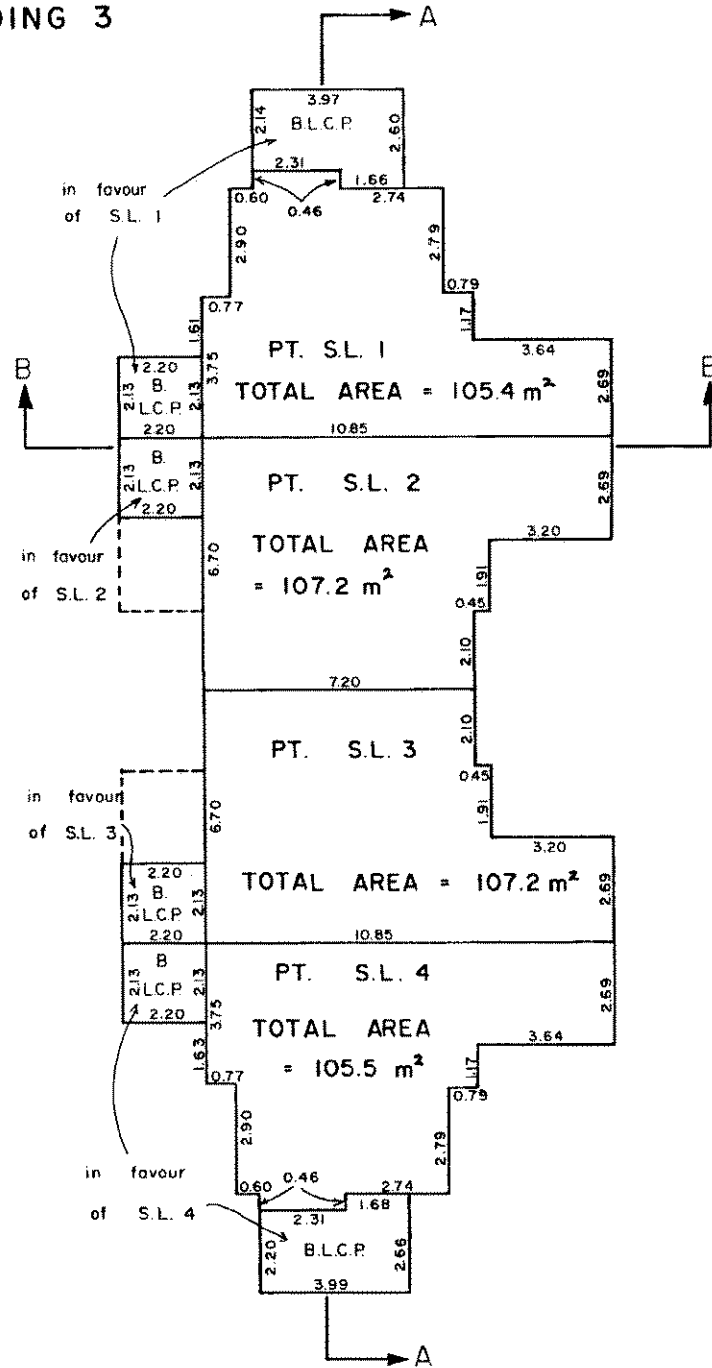

PLAN OF SECOND FLOOR

NOTE:
 S.L. DENOTES STRATA LOT
 C.P. DENOTES COMMON PROPERTY
 C.F. DENOTES COMMON FACILITY
 L.C.P. DENOTES LIMITED COMMON PROPERTY
 B. DENOTES BALCONY
 BALCONIES ARE COMMON PROPERTY AND ARE NOT INCLUDED IN SQUARE METRE (M²) AREAS
 ALL DISTANCES ARE IN METRES.

JP B.C.L.S.
 December 7, 1987.

FILED VAVAS2055 187418 2003-10-16-11.54.16.480949

PLAN OF STRATA LOTS 5 & 6

PHASE I

STRATA PLAN VR 2055

SCALE 1 : 125

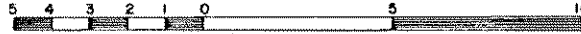

BUILDING 3

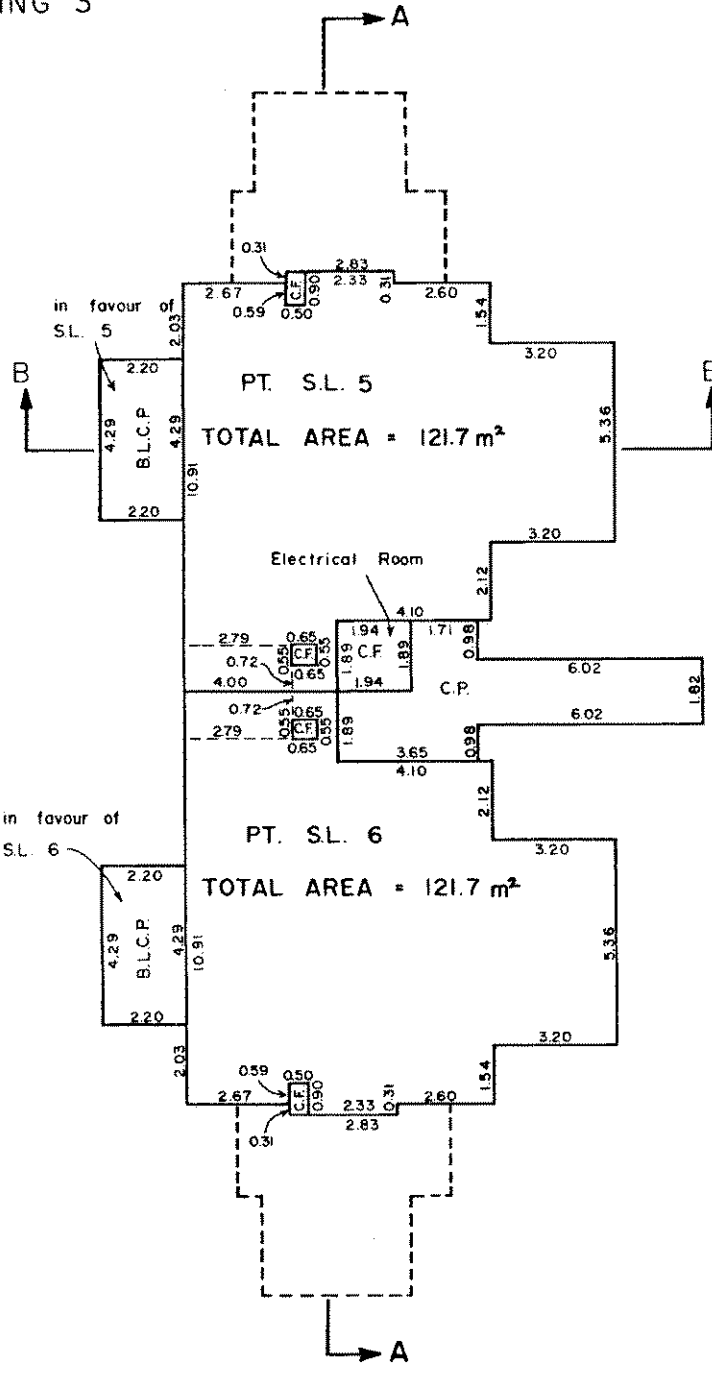

PLAN OF THIRD FLOOR



NOTE:
 S.L. DENOTES STRATA LOT
 C.P. DENOTES COMMON PROPERTY
 C.F. DENOTES COMMON FACILITY
 L.C.P. DENOTES LIMITED COMMON PROPERTY
 B. DENOTES BALCONY
 BALCONIES ARE COMMON PROPERTY AND ARE NOT INCLUDED IN SQUARE METRE (M²) AREAS
 ALL DISTANCES ARE IN METRES.

BB
 B.C.L.S.
 December 7, 1987.

FILED VAVAS2055 L82418 2003-10-16-11.54.16.488943

PLAN OF STRATA LOTS 5 & 6

PHASE I

STRATA PLAN VR 2055

SCALE 1 : 125

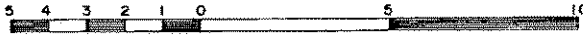

BUILDING 3

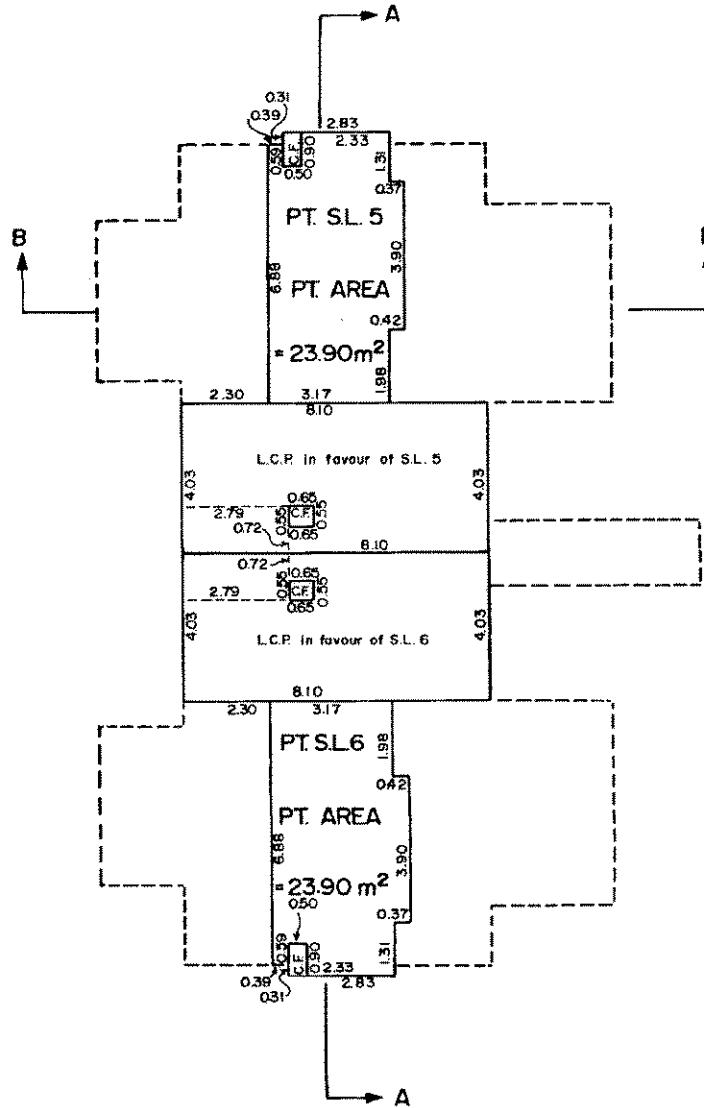

PLAN OF FOURTH FLOOR

NOTE:
 S.L. DENOTES STRATA LOT
 C.P. DENOTES COMMON PROPERTY
 C.F. DENOTES COMMON FACILITY
 L.C.P. DENOTES LIMITED COMMON PROPERTY
 B. DENOTES BALCONY
 BALCONIES ARE COMMON PROPERTY AND ARE NOT INCLUDED IN SQUARE METRE (M²) AREAS
 ALL DISTANCES ARE IN METRES.

BB
 B.C.L.S.
 December 7, 1987.

FILED VAVAS2055 2003-10-16-11.54.16.480949

FILED

PLAN OF STRATA LOTS 7 & 9

PHASE I

STRATA PLAN VR 2055

SCALE 1 : 125

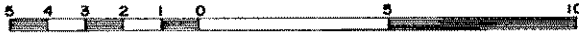

BUILDING 4

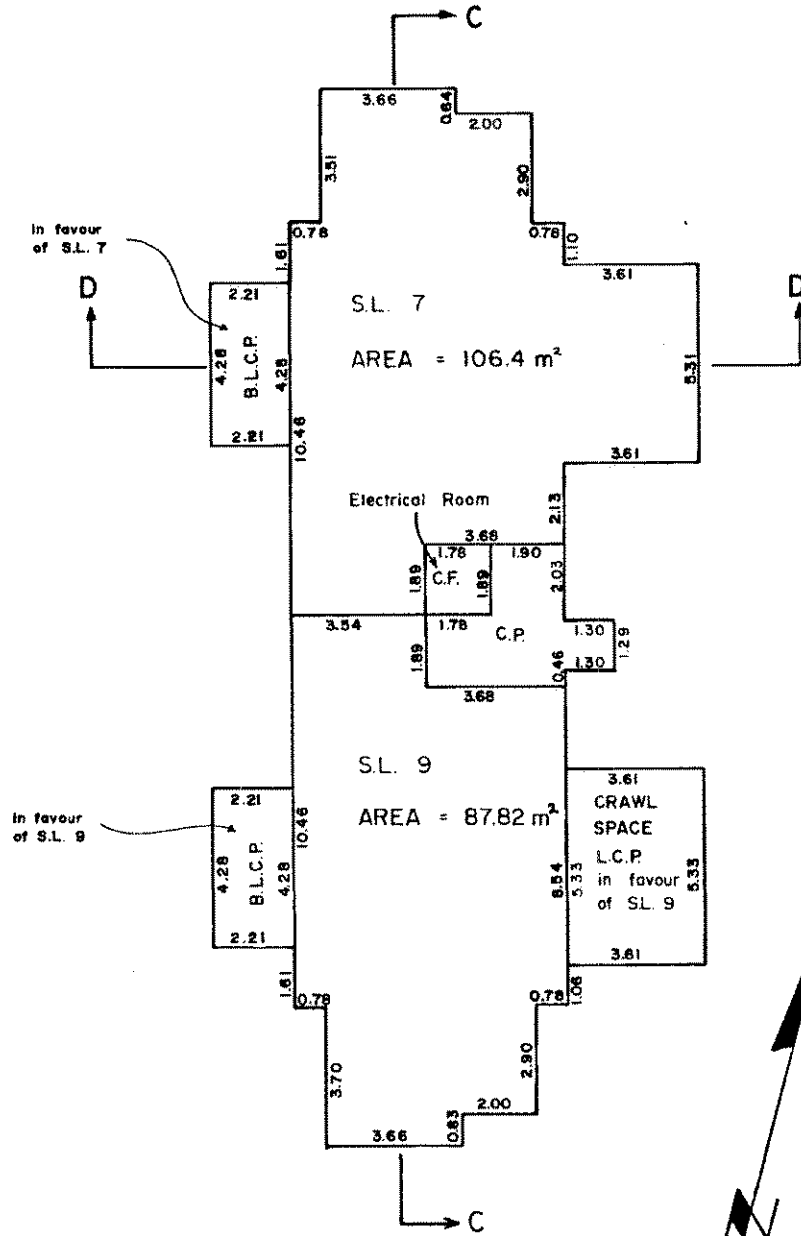

PLAN OF GROUND FLOOR

NOTE :

- C. F. DENOTES COMMON FACILITY
 - S. L. DENOTES STRATA LOT
 - C. P. DENOTES COMMON PROPERTY
 - L. C. P. DENOTES LIMITED COMMON PROPERTY
 - B. DENOTES BALCONY
- BALCONIES ARE COMMON PROPERTY AND ARE NOT INCLUDED IN SQUARE METRE (M²) AREAS
ALL DISTANCES ARE IN METRES.

B. C. L. S.

December 7, 1987.

L82418 2003-10-16-11.54.16.480949

VAVAS2055

FILED

PLAN OF STRATA LOTS 8 & 10

PHASE I

STRATA PLAN VR 2055

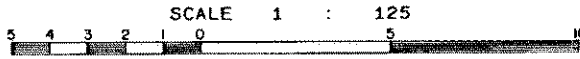

BUILDING 4

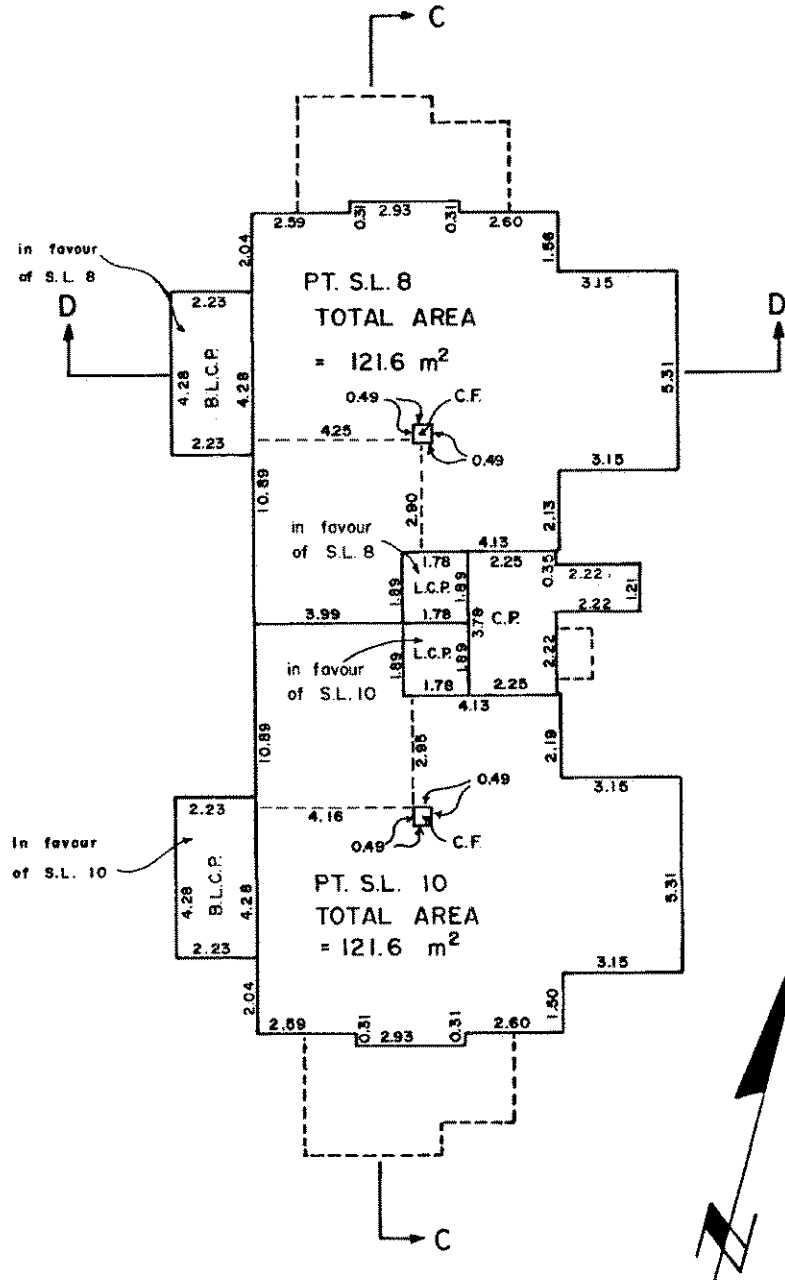

PLAN OF SECOND FLOOR

NOTE:
 S.L. DENOTES STRATA LOT
 C.P. DENOTES COMMON PROPERTY
 C.F. DENOTES COMMON FACILITY
 L.C.P. DENOTES LIMITED COMMON PROPERTY
 B. DENOTES BALCONY
 BALCONIES ARE COMMON PROPERTY AND ARE NOT INCLUDED IN SQUARE METRE (M²) AREAS
 ALL DISTANCES ARE IN METRES.

SP
 B.C.L.S.
 December 7, 1987.

L87418 2003-10-16-11.54.16.480949

VAVAS2055

FILED

PLAN OF STRATA LOTS 8 & 10

PHASE I

STRATA PLAN VR 2055

SCALE 1 : 125

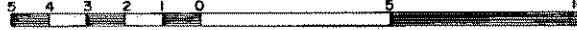

BUILDING 4

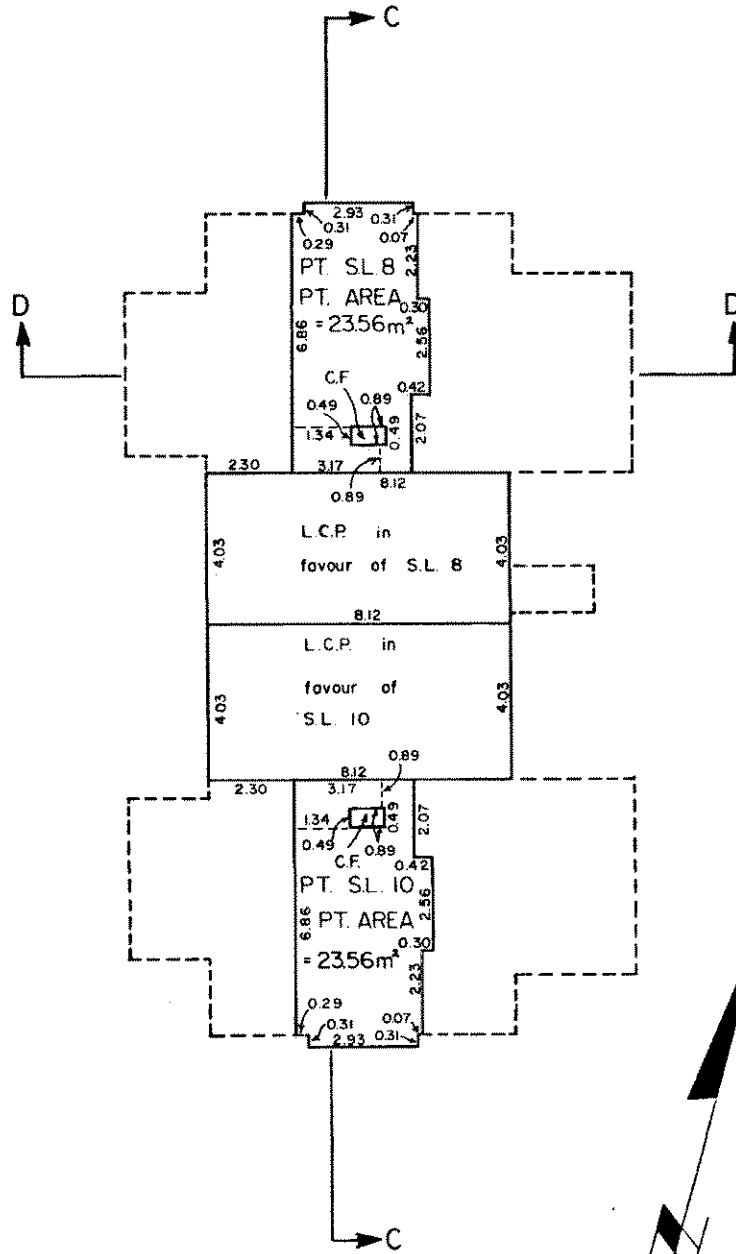

PLAN OF THIRD FLOOR

NOTE:
 S.L. DENOTES STRATA LOT
 C.P. DENOTES COMMON PROPERTY
 C.F. DENOTES COMMON FACILITY
 L.C.P. DENOTES LIMITED COMMON PROPERTY
 B. DENOTES BALCONY
 BALCONIES ARE COMMON PROPERTY AND ARE NOT INCLUDED IN SQUARE METRE (M²) AREAS
 ALL DISTANCES ARE IN METRES.

BB
 B.C.L.S.
 December 7, 1987.

FILED VAVAS2055 L82418 2003-10-16-11.54.16.480948

PLAN OF STRATA LOTS 13 & 16

PHASE I

STRATA PLAN VR 2055

SCALE 1 : 125



BUILDING 8

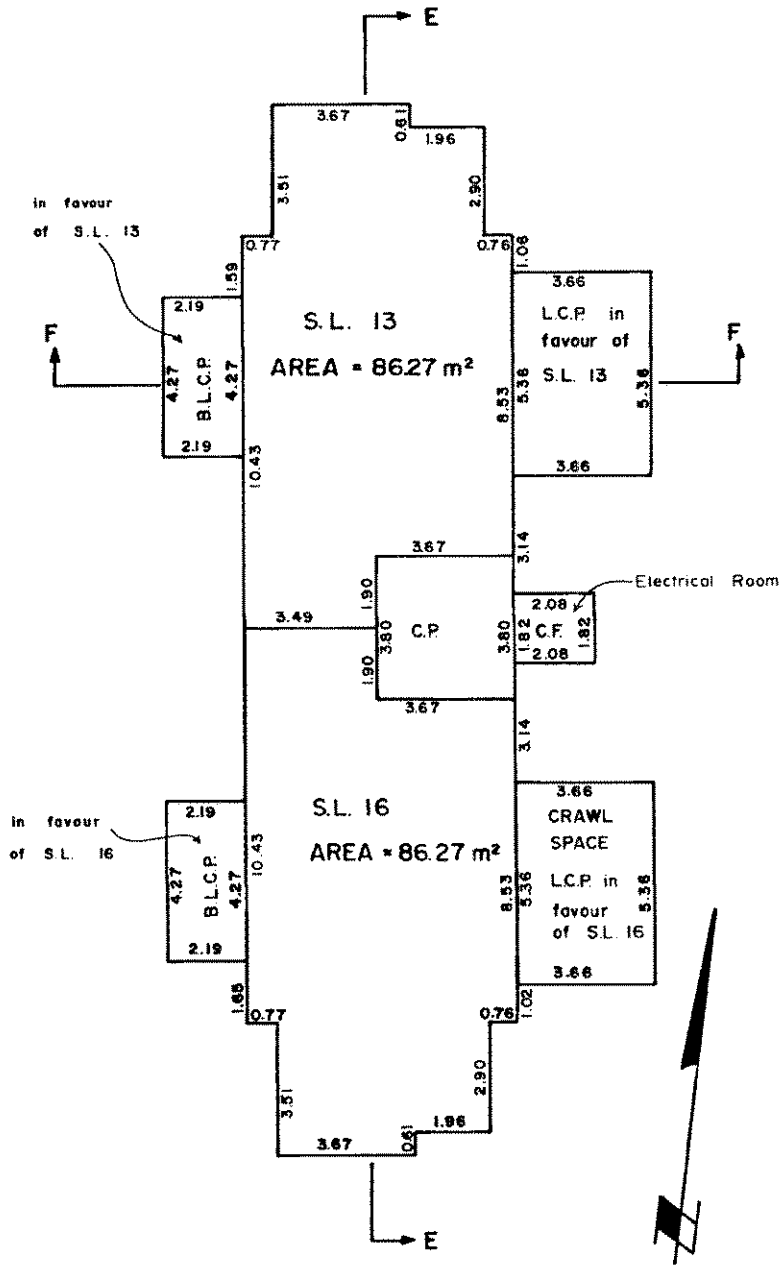

PLAN OF GROUND FLOOR

NOTE:
 S.L. DENOTES STRATA LOT
 C.P. DENOTES COMMON PROPERTY
 C.F. DENOTES COMMON FACILITY
 L.C.P. DENOTES LIMITED COMMON PROPERTY
 B. DENOTES BALCONY
 BALCONIES ARE COMMON PROPERTY AND ARE NOT INCLUDED IN SQUARE METRE (M²) AREAS
 ALL DISTANCES ARE IN METRES.

BB B.C.L.S.
 December 7, 1987.

L82410 2003-10-16-11.54.16.480949

VAVAS2055

FILED

PLAN OF STRATA LOTS 12 & 15

PHASE I

STRATA PLAN VR 2055

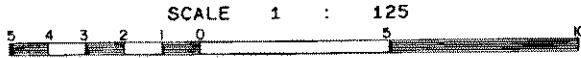

BUILDING 8

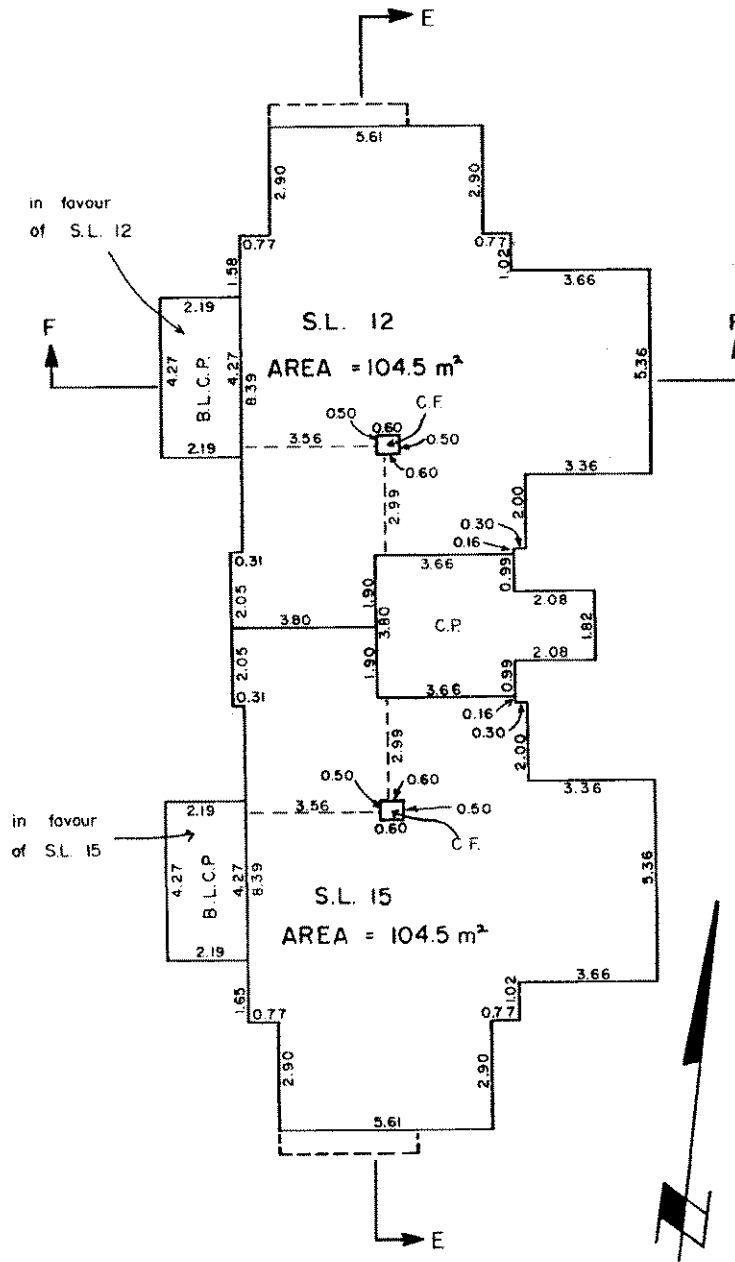

in favour of S.L. 12

in favour of S.L. 15

PLAN OF SECOND FLOOR

NOTE:
 S.L. DENOTES STRATA LOT
 C.P. DENOTES COMMON PROPERTY
 C.F. DENOTES COMMON FACILITY
 L.C.P. DENOTES LIMITED COMMON PROPERTY
 B. DENOTES BALCONY
 BALCONIES ARE COMMON PROPERTY AND ARE NOT INCLUDED IN SQUARE METRE (M²) AREAS
 ALL DISTANCES ARE IN METRES.

BB B.C.L.S.
 December 7, 1987.

FILED VAVAS2055 2003-10-16-11.54.16.480949

FILED

PLAN OF STRATA LOTS II 8 14

PHASE I

STRATA PLAN VR 2055

SCALE 1 : 125

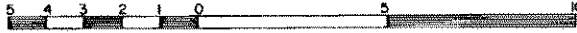

BUILDING 8

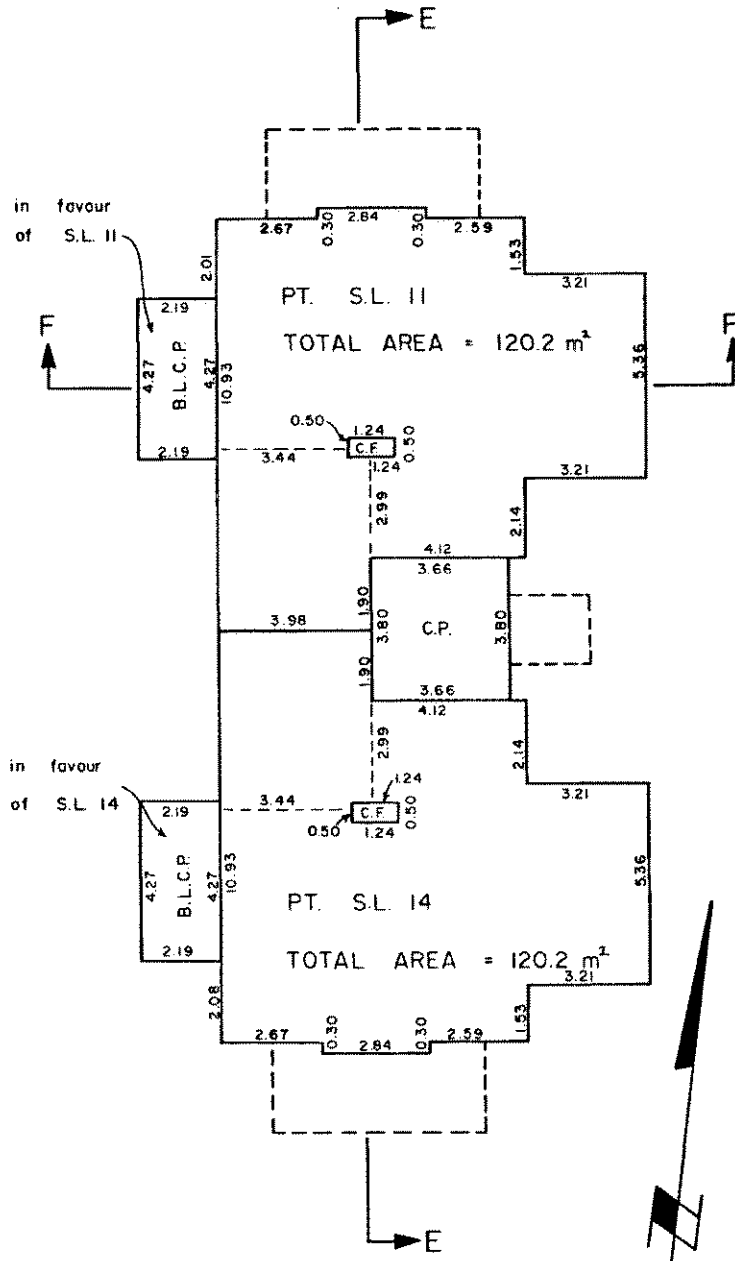

PLAN OF THIRD FLOOR

NOTE:
 S.L. DENOTES STRATA LOT
 C.P. DENOTES COMMON PROPERTY
 C.F. DENOTES COMMON FACILITY
 L.C.P. DENOTES LIMITED COMMON PROPERTY
 B. DENOTES BALCONY
 BALCONIES ARE COMMON PROPERTY AND ARE NOT INCLUDED IN SQUARE METRE (M²) AREAS
 ALL DISTANCES ARE IN METRES.

BB
 B.C.L.S.
 December 7, 1987.

FILED VAVAS2055 182418 2003-10-16-11.54.16.480949

PLAN OF STRATA LOTS II & 14

PHASE I

STRATA PLAN VR 2055

SCALE 1 : 125

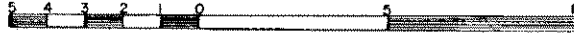

BUILDING 8

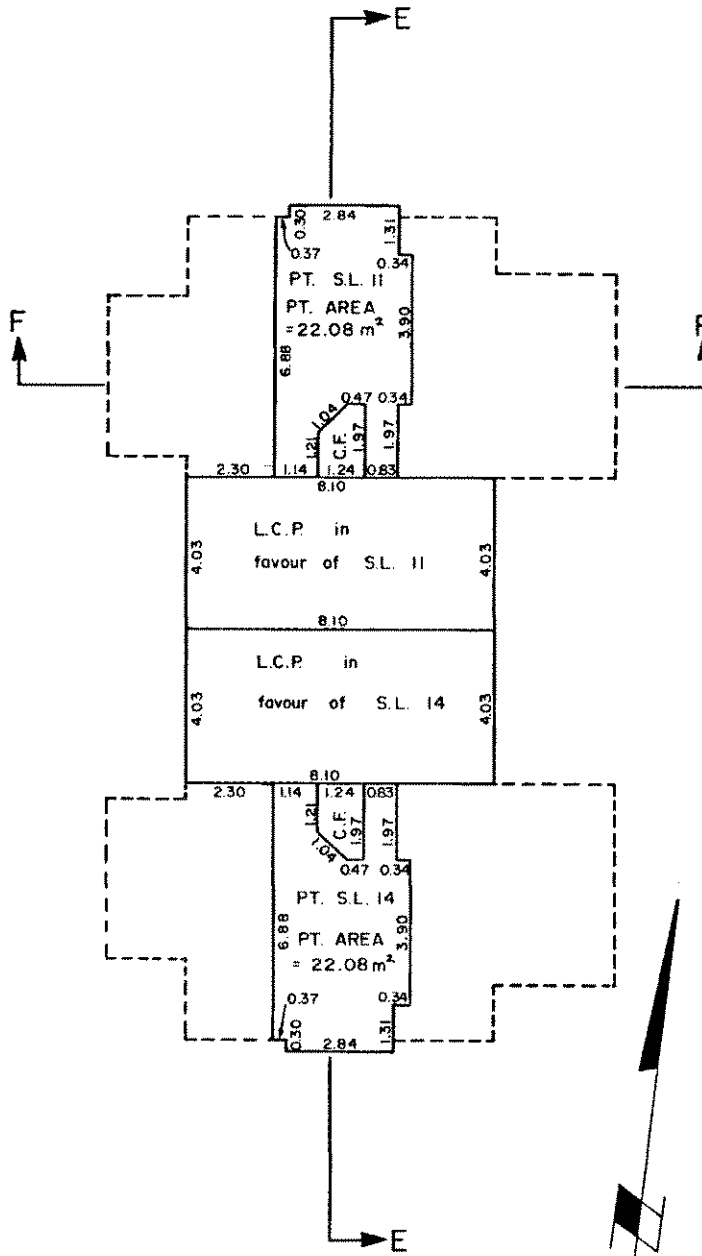

PLAN OF FOURTH FLOOR

NOTE:
 S.L. DENOTES STRATA LOT
 C.P. DENOTES COMMON PROPERTY
 C.F. DENOTES COMMON FACILITY
 L.C.P. DENOTES LIMITED COMMON PROPERTY
 B. DENOTES BALCONY
 BALCONIES ARE COMMON PROPERTY AND ARE NOT INCLUDED IN SQUARE METRE (M²) AREAS
 ALL DISTANCES ARE IN METRES.

FB B.C.L.S.
 December 7, 1987.

FILED VAVAS2055 182418 2003-10-16-11.54.16.480949

PLAN OF LCP FOR STRATA LOTS 17, 18 & 19 PHASE I
STRATA PLAN VR 2055



BUILDING 9

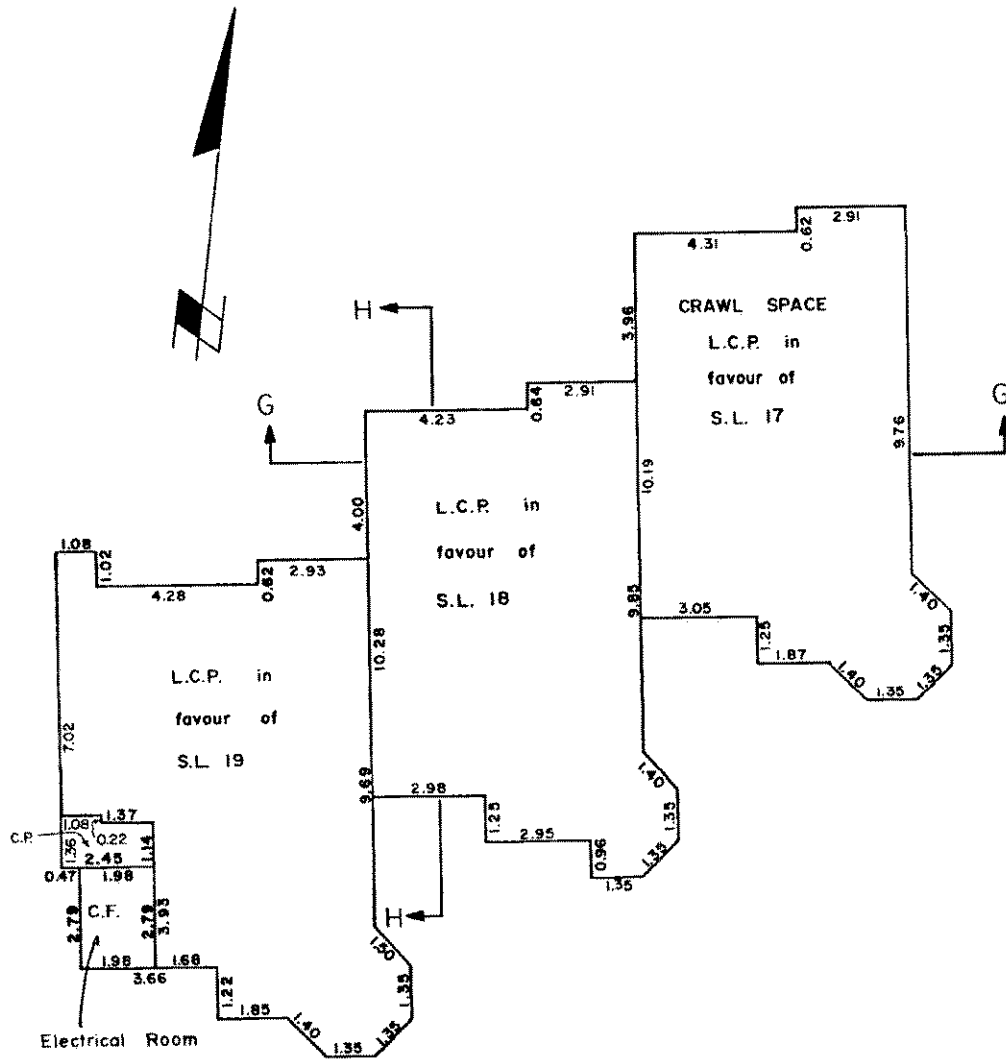

PLAN OF BASEMENT

NOTE:
S.L. DENOTES STRATA LOT
C.P. DENOTES COMMON PROPERTY
C.F. DENOTES COMMON FACILITY
L.C.P. DENOTES LIMITED COMMON PROPERTY
B. DENOTES BALCONY
BALCONIES ARE COMMON PROPERTY AND ARE NOT INCLUDED IN SQUARE METRE (M²) AREAS
ALL DISTANCES ARE IN METRES.

BP B.C.L.S.
December 7, 1987.

L82418 2003-10-16-11-54-16.480949

VAVAS2055

FILED

PLAN OF STRATA LOTS 17, 18 & 19

PHASE I

STRATA PLAN VR 2055

SCALE 1 : 125

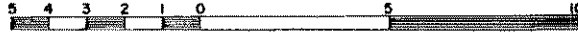

BUILDING 9

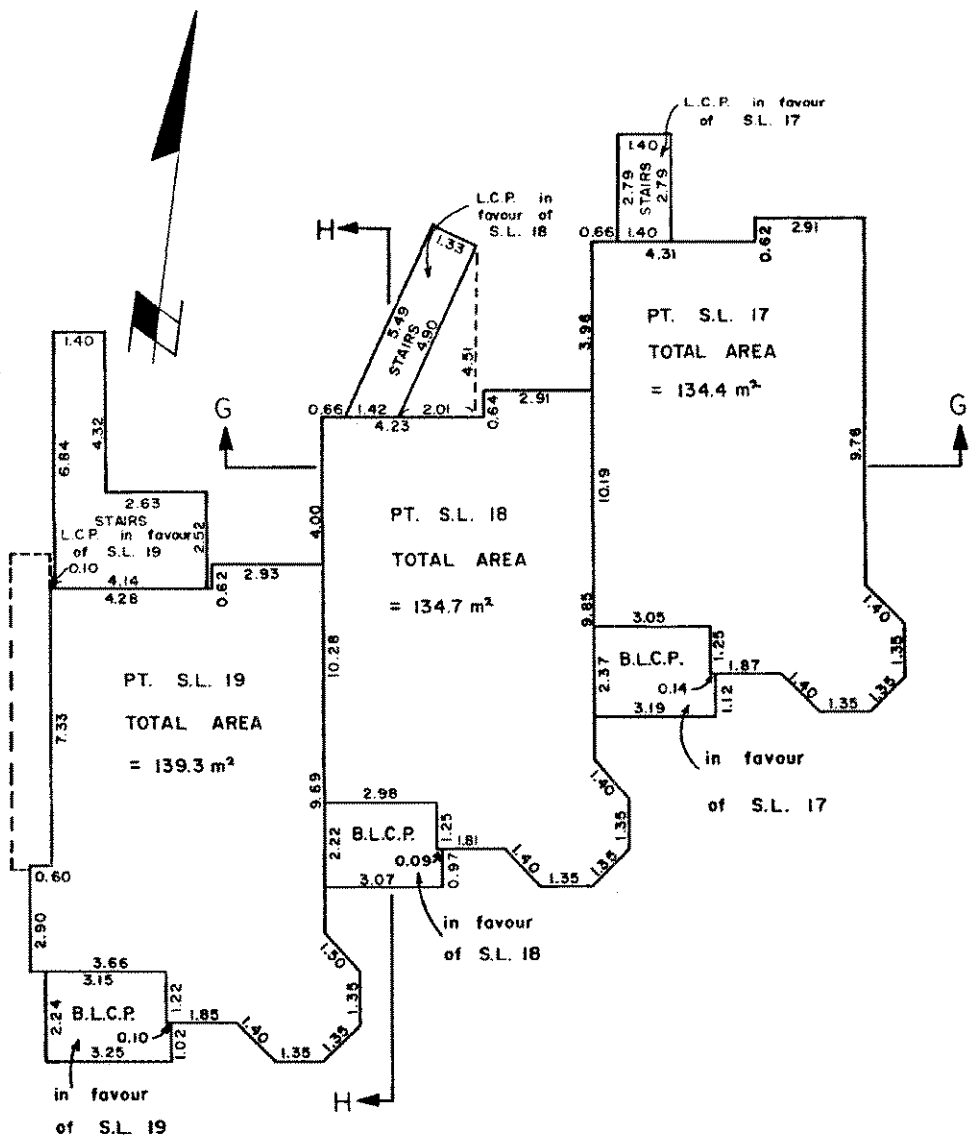

PLAN OF GROUND FLOOR

NOTE:
 S.L. DENOTES STRATA LOT
 C.P. DENOTES COMMON PROPERTY
 C.F. DENOTES COMMON FACILITY
 L.C.P. DENOTES LIMITED COMMON PROPERTY
 B. DENOTES BALCONY
 BALCONIES ARE COMMON PROPERTY AND ARE NOT INCLUDED IN SQUARE METRE (M²) AREAS
 ALL DISTANCES ARE IN METRES.

BB
 B.C.L.S.
 December 7, 1987

FILED VAVAS2055 182418 2003-10-16-11.54.16.480949

PLAN OF STRATA LOTS 17, 18 & 19

PHASE I

STRATA PLAN VR 2055

SCALE 1 : 125



BUILDING 9

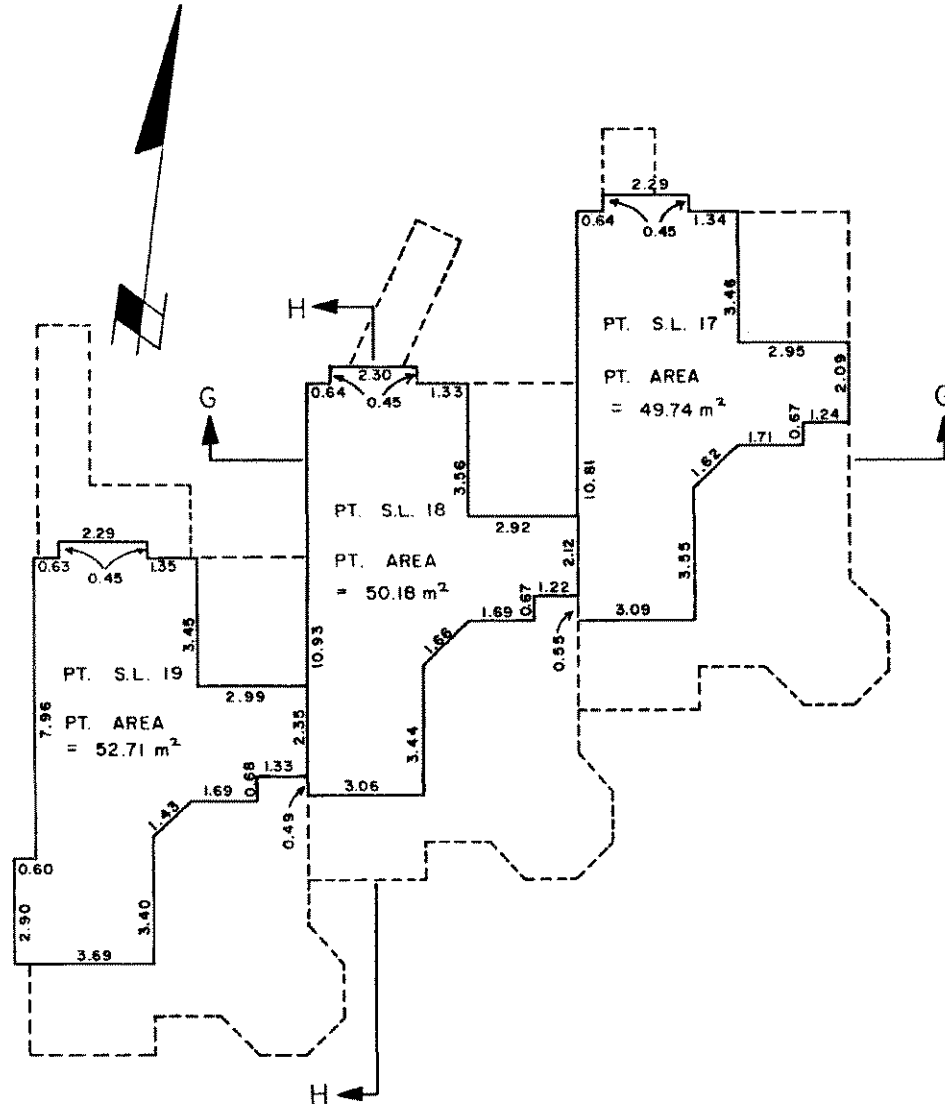

PLAN OF SECOND FLOOR

NOTE:
 S.L. DENOTES STRATA LOT
 C.P. DENOTES COMMON PROPERTY
 C.F. DENOTES COMMON FACILITY
 L.C.P. DENOTES LIMITED COMMON PROPERTY
 B. DENOTES BALCONY
 BALCONIES ARE COMMON PROPERTY AND ARE NOT INCLUDED IN SQUARE METRE (M²) AREAS
 ALL DISTANCES ARE IN METRES.

B.C.L.S.

BB
 December 7, 1987.

FILED VAVAS2055 182418 2003-10-16-11.54.16.480949

PLAN OF STRATA LOTS 20 & 23

PHASE I

STRATA PLAN VR 2055

SCALE 1 : 125

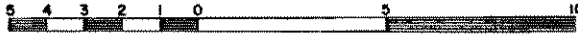

BUILDING 10

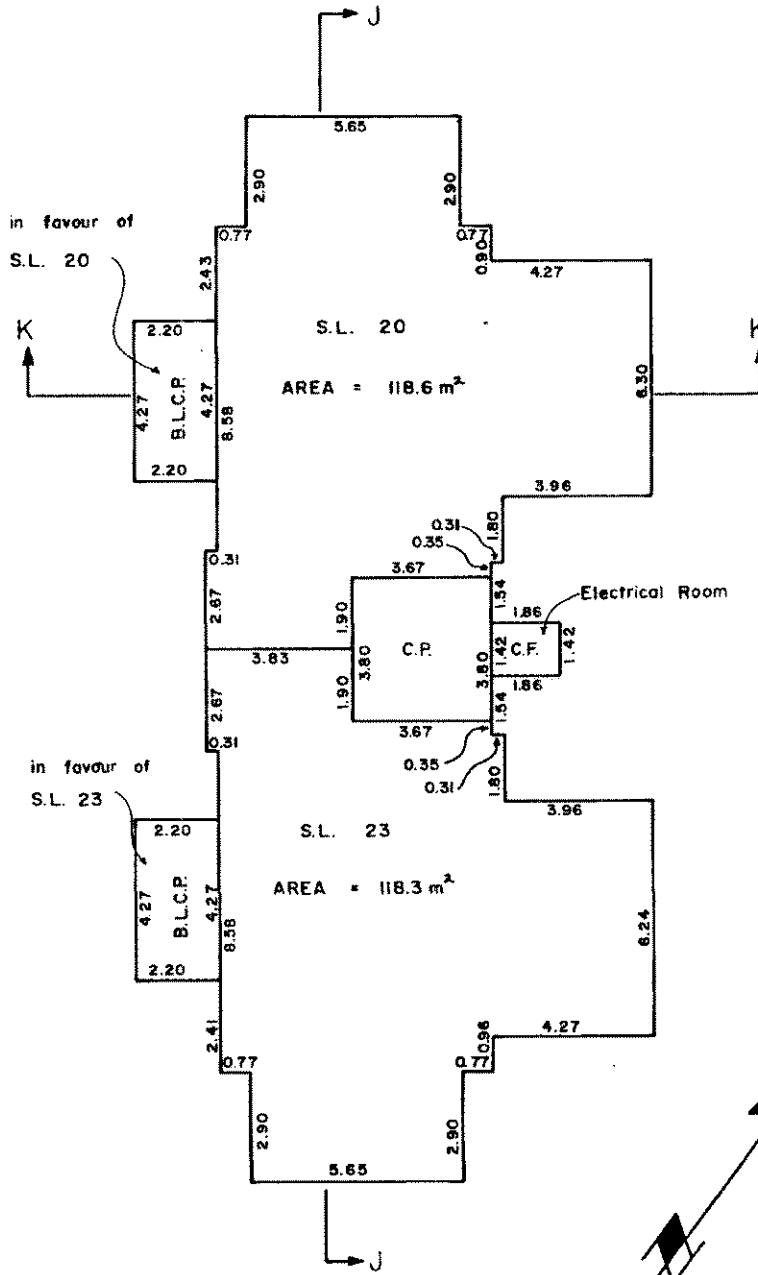

PLAN OF GROUND FLOOR

NOTE:
 S.L. DENOTES STRATA LOT
 C.P. DENOTES COMMON PROPERTY
 C.F. DENOTES COMMON FACILITY
 L.C.P. DENOTES LIMITED COMMON PROPERTY
 B. DENOTES BALCONY
 BALCONIES ARE COMMON PROPERTY AND ARE NOT INCLUDED IN SQUARE METRE (m²) AREAS
 ALL DISTANCES ARE IN METRES.

BB
 ----- B.C.L.S.
December 7, 1987.

L82418 2003-10-16-11.54.15.480949

VAVAS2055

FILED

PLAN OF STRATA LOTS 21 & 24

PHASE I

STRATA PLAN VR 2055

SCALE 1 : 125

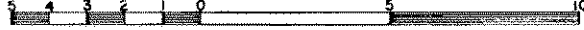

BUILDING 10

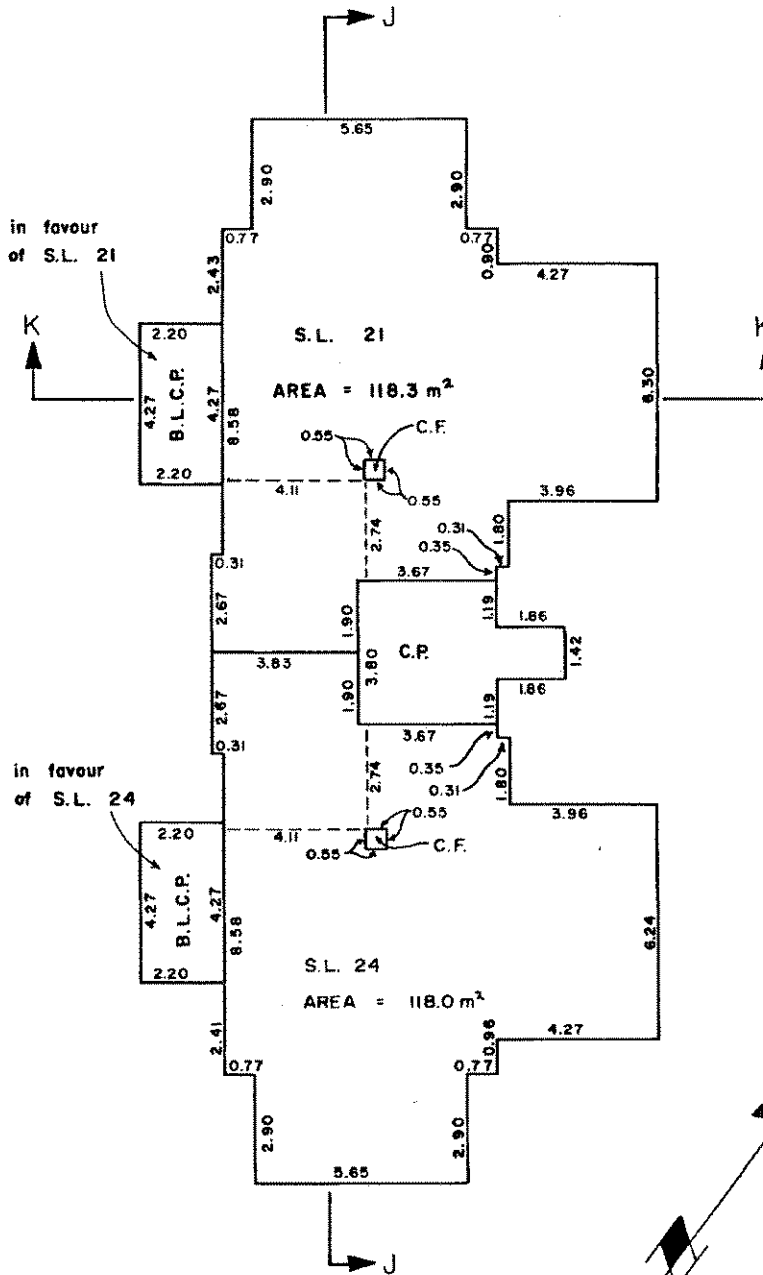

PLAN OF SECOND FLOOR

NOTE:
 S.L. DENOTES STRATA LOT
 C.P. DENOTES COMMON PROPERTY
 C.F. DENOTES COMMON FACILITY
 L.C.P. DENOTES LIMITED COMMON PROPERTY
 B. DENOTES BALCONY
 BALCONIES ARE COMMON PROPERTY AND ARE NOT INCLUDED IN SQUARE METRE (M²) AREAS
 ALL DISTANCES ARE IN METRES.

BB B.C.L.S.
 December 7, 1987.

L82418 2003-10-16-11.54.16.480949

VAVAS2055

FILED

PLAN OF STRATA LOTS 22 & 25

PHASE I

STRATA PLAN VR 2066

SCALE 1 : 125



BUILDING 10

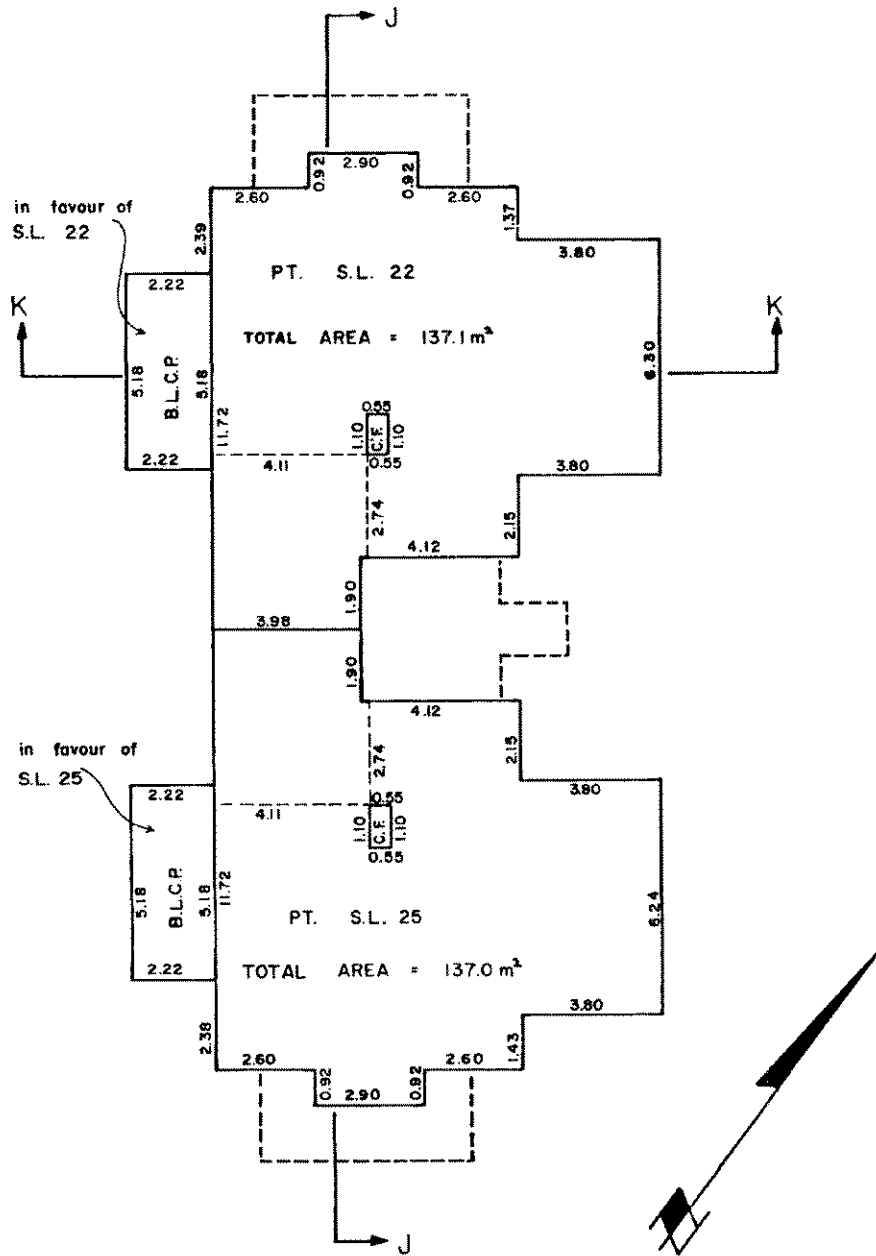

in favour of S.L. 22

in favour of S.L. 25

PLAN OF THIRD FLOOR

NOTE:
 S.L. DENOTES STRATA LOT
 C.P. DENOTES COMMON PROPERTY
 C.F. DENOTES COMMON FACILITY
 L.C.P. DENOTES LIMITED COMMON PROPERTY
 B. DENOTES BALCONY
 BALCONIES ARE COMMON PROPERTY AND ARE NOT INCLUDED IN SQUARE METRE (M²) AREAS
 ALL DISTANCES ARE IN METRES.

FB B.C.L.S.
 December 7, 1987.

FILED VAVAS2055 1.82418 2003-10-16-11.54.16.480949

PLAN OF STRATA LOTS 22 & 25

PHASE I

STRATA PLAN VR 2055

SCALE 1 : 125

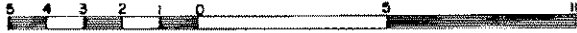

BUILDING 10

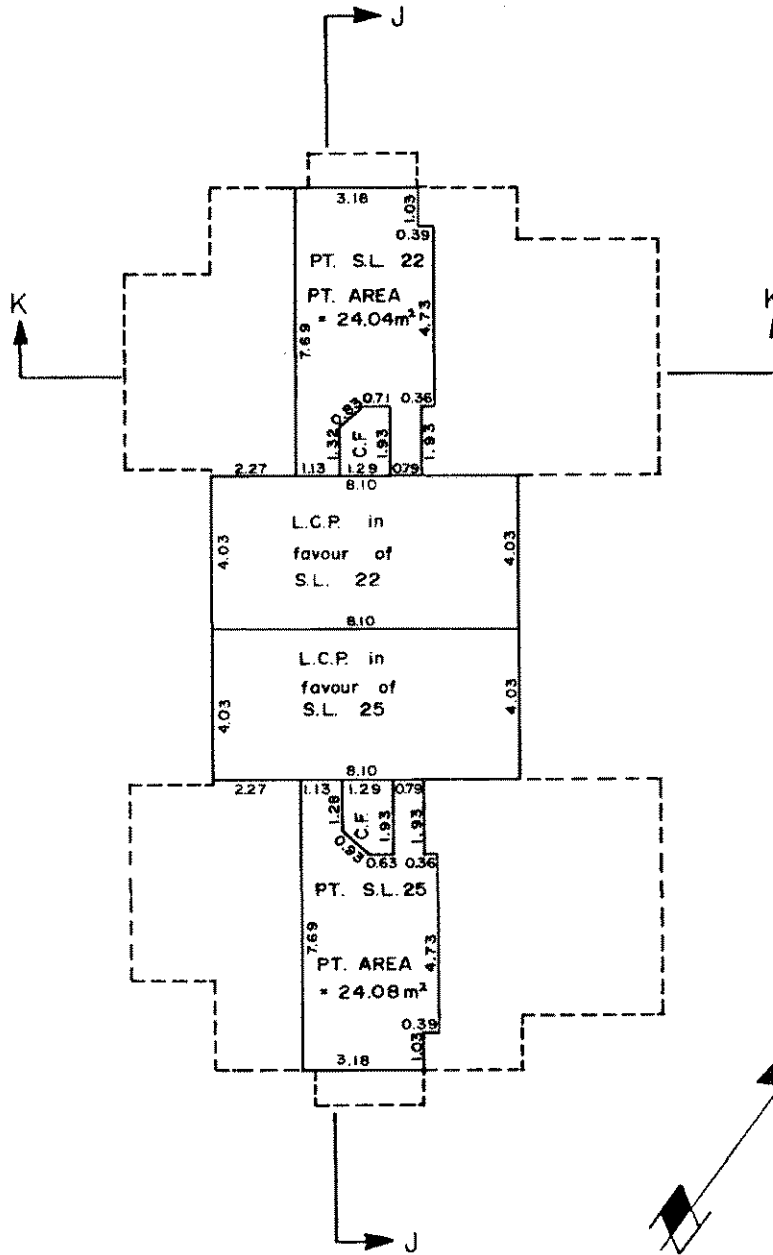

PLAN OF FOURTH FLOOR

NOTE:
 S.L. DENOTES STRATA LOT
 C.P. DENOTES COMMON PROPERTY
 C.F. DENOTES COMMON FACILITY
 L.C.P. DENOTES LIMITED COMMON PROPERTY
 B. DENOTES BALCONY
 BALCONIES ARE COMMON PROPERTY AND ARE NOT INCLUDED IN SQUARE METRE (M²) AREAS
 ALL DISTANCES ARE IN METRES.

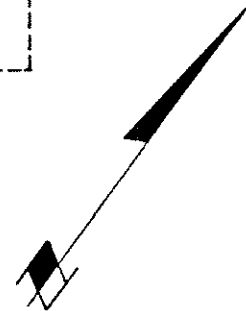

BB
 B.C.L.S.
 December 7, 1987.

FILED VAVAS2055 182418 2003-10-16-11.54.16.480949

CROSS-SECTIONS

PHASE I

STRATA PLAN VR 2055

SCALE 1 : 125

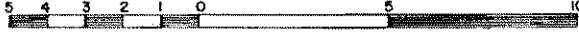

BUILDING 3

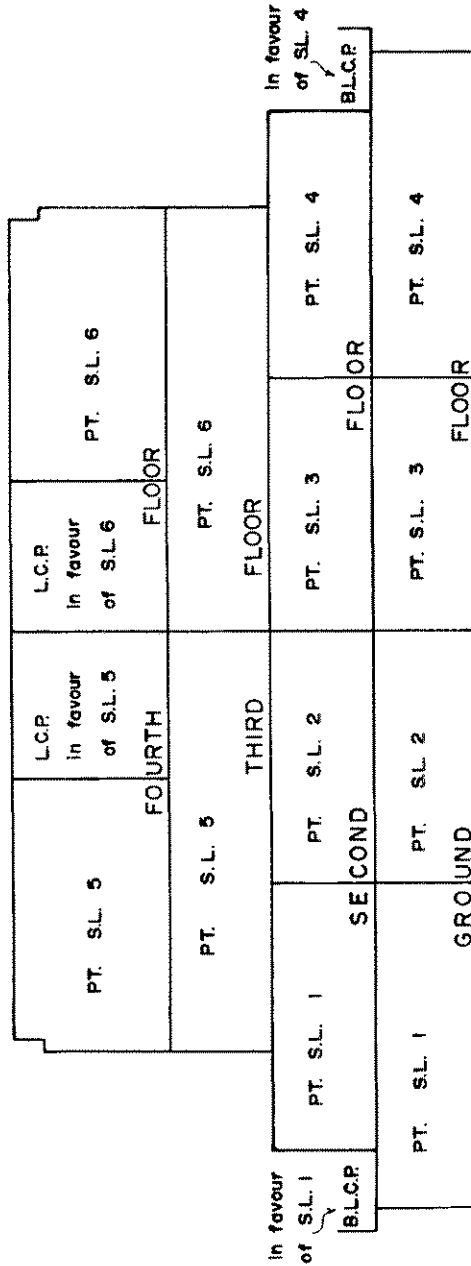

CROSS-SECTION 'A' - 'A'

NOTE:
 S.L. DENOTES STRATA LOT
 C.P. DENOTES COMMON PROPERTY
 C.F. DENOTES COMMON FACILITY
 L.C.P. DENOTES LIMITED COMMON PROPERTY
 B. DENOTES BALCONY
 BALCONIES ARE COMMON PROPERTY AND ARE NOT INCLUDED IN SQUARE METRE (M²) AREAS
 ALL DISTANCES ARE IN METRES.

BB

B.C.L.S.

December 7, 1987.

FILED VAVAS2055 L82418 2003-10-16-11.54.15.480949

CROSS-SECTIONS

PHASE I

SCALE 1 : 125

STRATA PLAN VR 2055

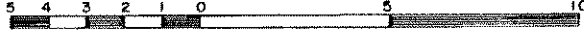

BUILDING 3

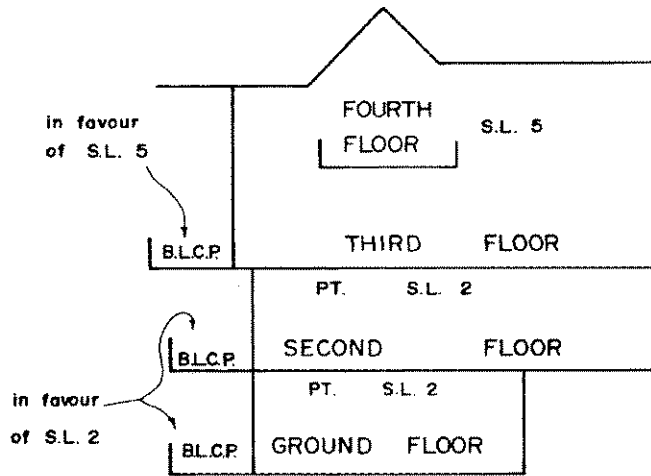

CROSS-SECTION 'B'-'B'

NOTE:
 S.L. DENOTES STRATA LOT
 C.P. DENOTES COMMON PROPERTY
 C.F. DENOTES COMMON FACILITY
 L.C.P. DENOTES LIMITED COMMON PROPERTY
 B. DENOTES BALCONY
 BALCONIES ARE COMMON PROPERTY AND ARE NOT INCLUDED IN SQUARE METRE (M²) AREAS
 ALL DISTANCES ARE IN METRES.

BB B.C.L.S.
December 7, 1987.

FILED VAVAS2055 182418 2003-10-16-11.54.16.480949

CROSS-SECTIONS

PHASE I

STRATA PLAN VR 2055

SCALE 1 : 125



BUILDING 4

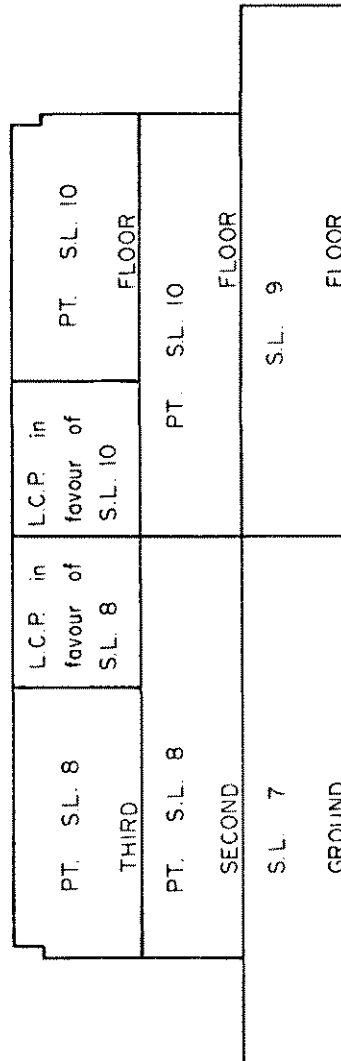

CROSS - SECTION 'C' - 'C'

NOTE:
 S.L. DENOTES STRATA LOT
 C.P. DENOTES COMMON PROPERTY
 C.F. DENOTES COMMON FACILITY
 L.C.P. DENOTES LIMITED COMMON PROPERTY
 B. DENOTES BALCONY
 BALCONIES ARE COMMON PROPERTY AND ARE NOT INCLUDED IN SQUARE METRE (M²) AREAS
 ALL DISTANCES ARE IN METRES.

B.C.L.S.

BB

December 7, 1987.

FILED VAVAS2055 2003-10-16-11.54.16.480949

CROSS-SECTIONS

PHASE I

STRATA PLAN VR 2055

SCALE 1 : 125



BUILDING 4

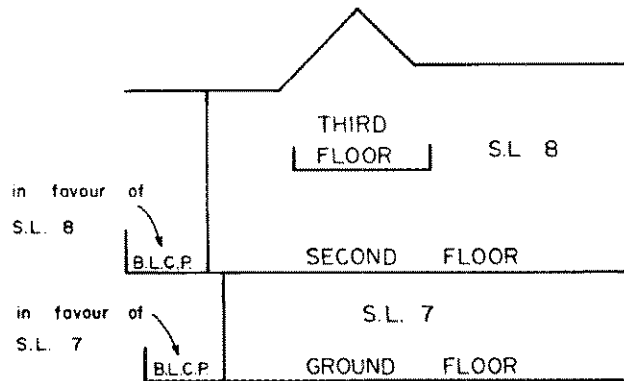

CROSS - SECTION 'D' - 'D'

NOTE:
 S.L. DENOTES STRATA LOT
 C.P. DENOTES COMMON PROPERTY
 C.F. DENOTES COMMON FACILITY
 L.C.P. DENOTES LIMITED COMMON PROPERTY
 B. DENOTES BALCONY
 BALCONIES ARE COMMON PROPERTY AND ARE NOT INCLUDED IN SQUARE METRE (M²) AREAS
 ALL DISTANCES ARE IN METRES.

BB

B.C.L.S.

December 7, 1987.

FILED VAVAS2055 L82418 2003-10-16-11.54.16.480949

CROSS-SECTIONS

PHASE I



STRATA PLAN VR 2055

BUILDING 8

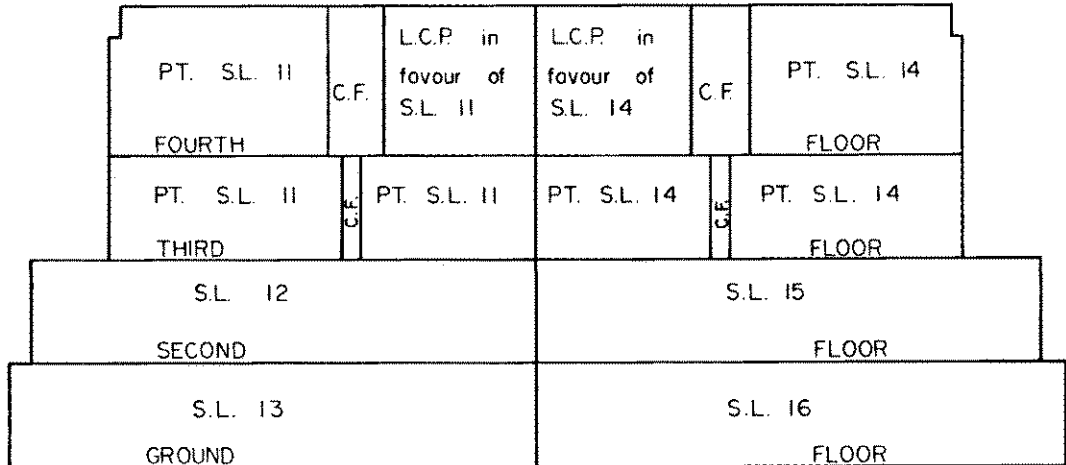

CROSS - SECTION 'E' - 'E'

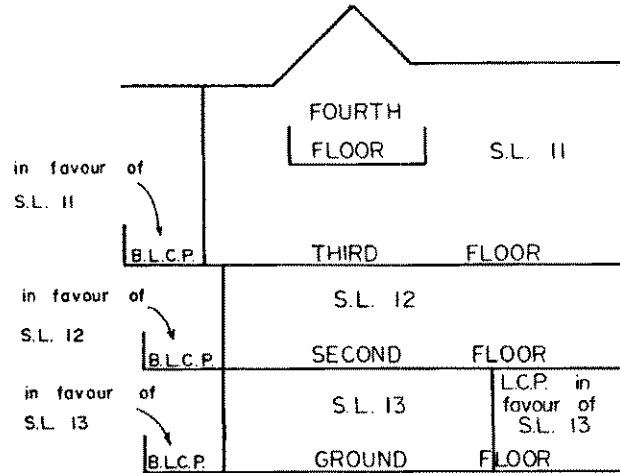

CROSS - SECTION 'F' - 'F'

NOTE:
 S.L. DENOTES STRATA LOT
 C.P. DENOTES COMMON PROPERTY
 C.F. DENOTES COMMON FACILITY
 L.C.P. DENOTES LIMITED COMMON PROPERTY
 B. DENOTES BALCONY
 BALCONIES ARE COMMON PROPERTY AND ARE NOT INCLUDED IN SQUARE METRE (M²) AREAS
 ALL DISTANCES ARE IN METRES.

BB
 B.C.L.S.
December 7, 1987.

L82418 2003-10-16-11.54.16.480949

VAVAS2055

FILED

CROSS-SECTIONS

PHASE I

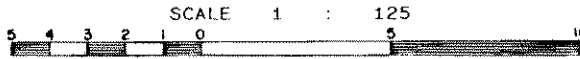

STRATA PLAN VR 2055

BUILDING 9

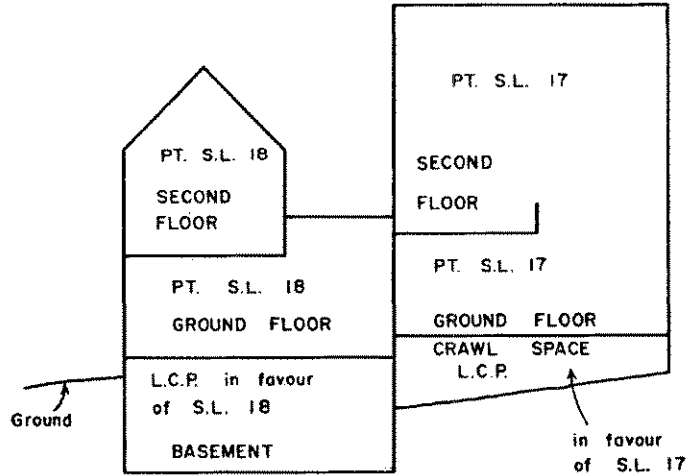

CROSS - SECTION 'G' - 'G'

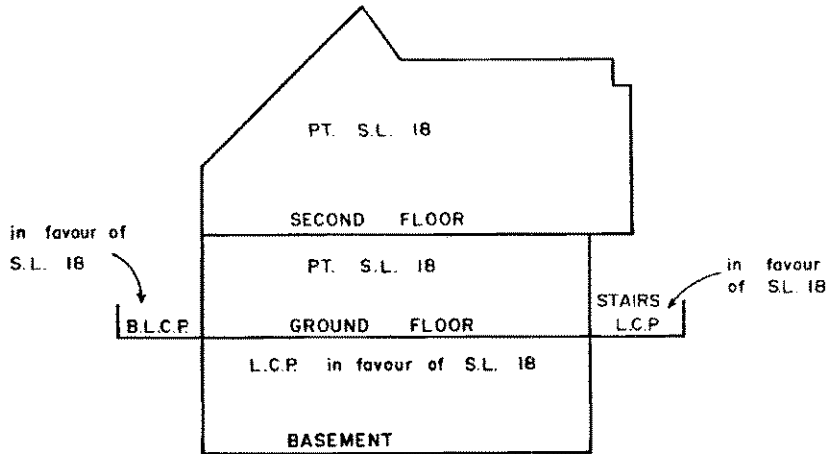

CROSS - SECTION 'H' - 'H'

NOTE:
 S.L. DENOTES STRATA LOT
 C.P. DENOTES COMMON PROPERTY
 C.F. DENOTES COMMON FACILITY
 L.C.P. DENOTES LIMITED COMMON PROPERTY
 B. DENOTES BALCONY
 BALCONIES ARE COMMON PROPERTY AND ARE NOT INCLUDED IN SQUARE METRE (M²) AREAS
 ALL DISTANCES ARE IN METRES.

BB
 B.C.L.S.
 December 7, 1987.

FILED 182418 2003-10-16-11.54.16.480949

VAVAS2055

FILED

CROSS-SECTIONS

PHASE I

SCALE 1 : 125

STRATA PLAN VR 2055



BUILDING 10

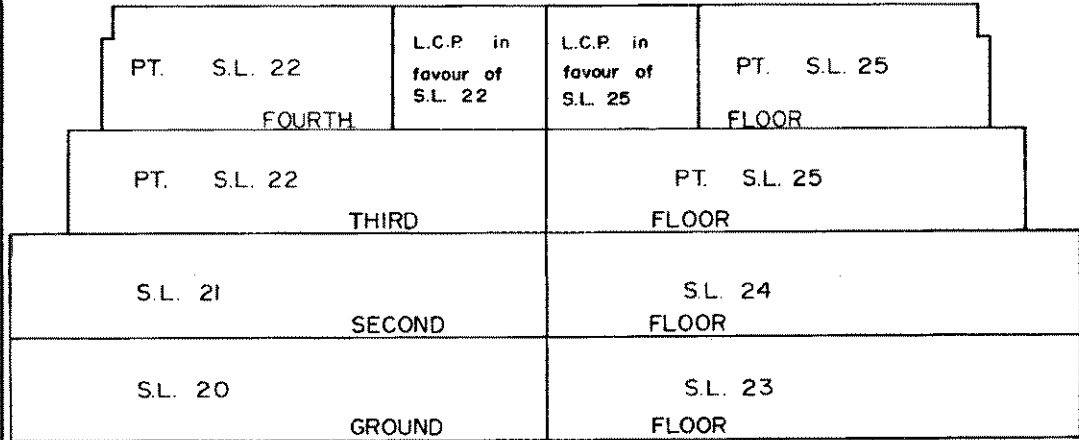

CROSS - SECTION 'J' - 'J'

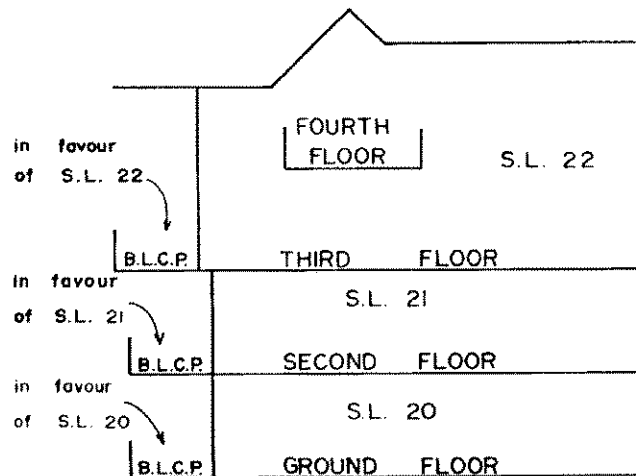

CROSS - SECTION 'K' - 'K'

NOTE:
 S.L. DENOTES STRATA LOT
 C.P. DENOTES COMMON PROPERTY
 C.F. DENOTES COMMON FACILITY
 L.C.P. DENOTES LIMITED COMMON PROPERTY
 B. DENOTES BALCONY
 BALCONIES ARE COMMON PROPERTY AND ARE NOT INCLUDED IN SQUARE METRE (M²) AREAS
 ALL DISTANCES ARE IN METRES.

JP
 B.C.L.S.
 December 7, 1987.

FILED 182418 2003-10-16-11.54.16.480949

VAVAS2055

FILED

PLAN OF LCP FOR STRATA LOTS
1,2,3,4,5,6,7,8,10 AND PART OF
LCP FOR STRATA LOT 9

SHEET 29 OF 33 SHEETS

PHASE I

STRATA PLAN V.R. 2055



SCALE : 1:250

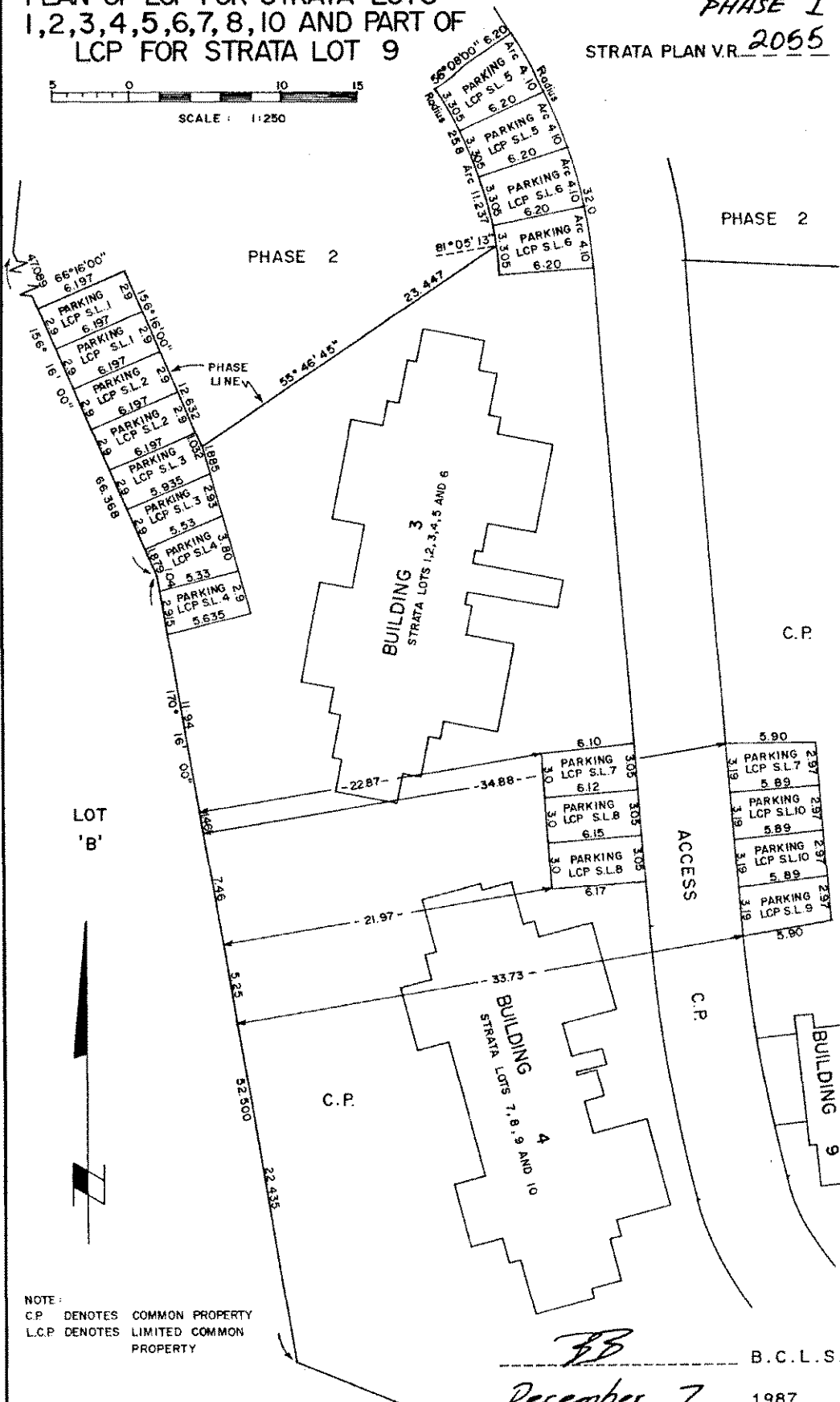

NOTE:
C.P. DENOTES COMMON PROPERTY
L.C.P. DENOTES LIMITED COMMON
PROPERTY

BB
December 7, 1987. B.C.L.S.

FILED VAVAS2055 182418 2003-10-16-11.54.16.480349

PLAN OF LCP FOR STRATA LOTS 11, 12, 13, 14, 15, 16, 17, 18 AND 19

PHASE I

STRATA PLAN VR. 2055

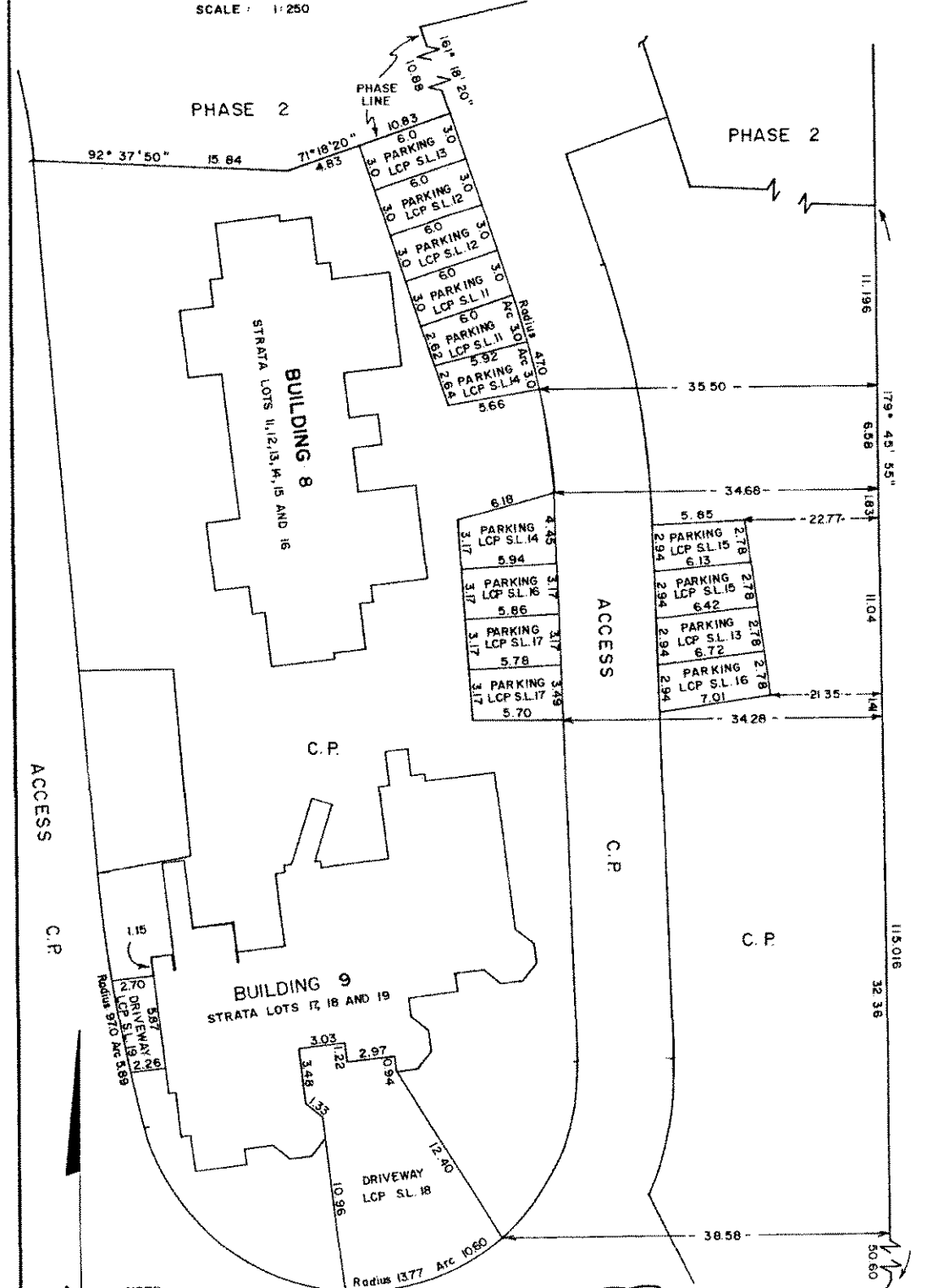

NOTE:
 C.P. DENOTES COMMON PROPERTY
 LCP DENOTES LIMITED COMMON PROPERTY

BP

B.C.L.S.

December 7, 1987.

FILED VAVAS2055 182418 2003-10-16-11.54.16.480949

FILED

PLAN OF LCP FOR STRATA LOTS
20, 21, 22, 23, 24, 25 AND PART OF
LCP FOR STRATA LOT 9

SHEET 31 OF 33 SHEETS

PHASE I

STRATA PLAN V.R. 2055



SCALE 1:250

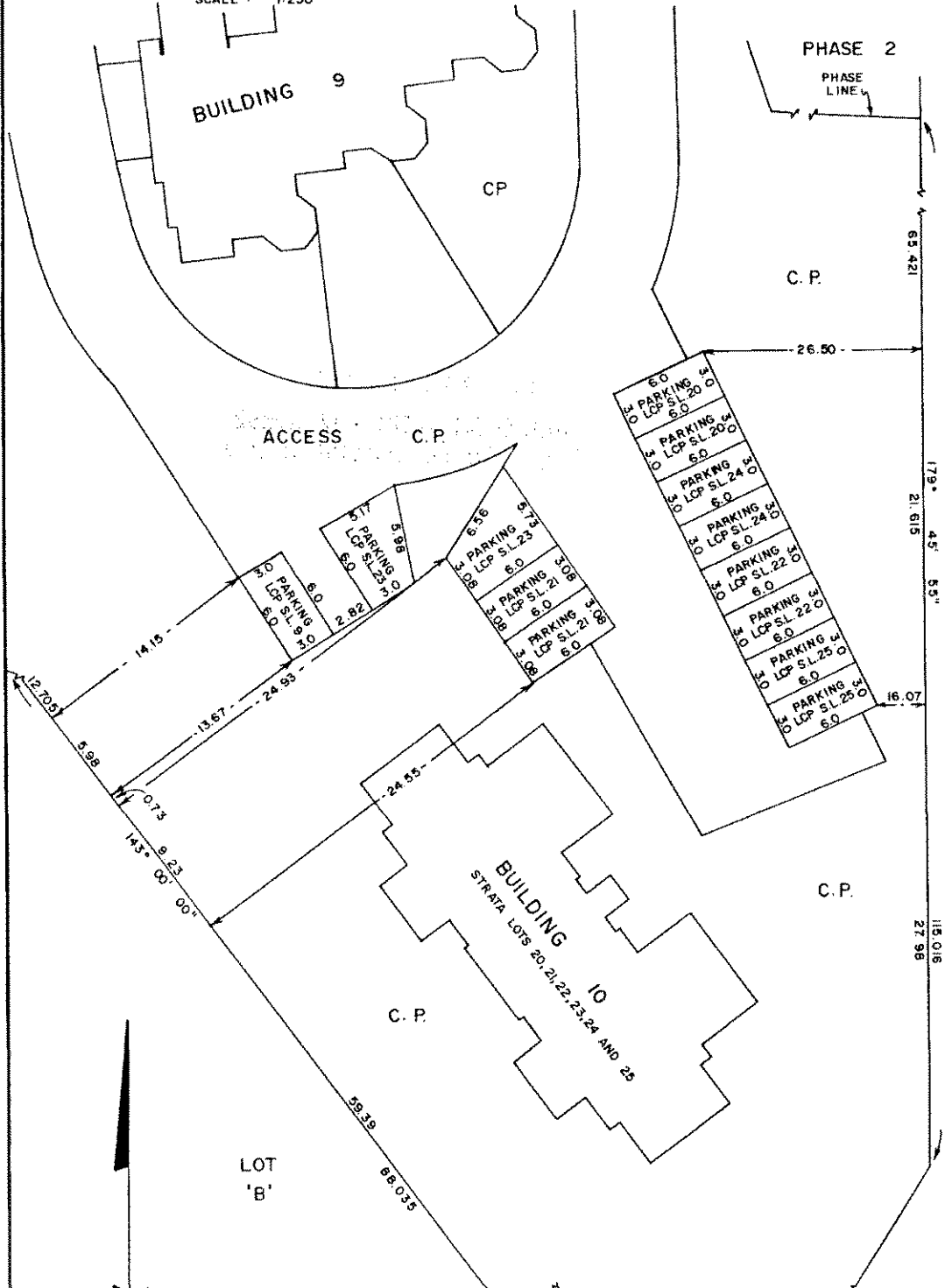

NOTE:
C.P. DENOTES COMMON PROPERTY
LCP DENOTES LIMITED COMMON PROPERTY

BB

B.C.L.S.

December 7, 1987.

FILED VAVAS2055 L82418 2003-10-16-11.54.16.480949

PHASE I

STRATA PLAN VR 2055

RECORD OF BY LAWS AND ORDERS , ETC.

FILING		DOCUMENT	
NUMBER	DATE	DATE	NATURE AND PARTICULARS
BF194576	May 24/92		Change of By Laws
BF194577	May 26/92		Change of By Laws
BT247301	21-08-95		NOTIFICATION OF CHANGE OF BYLAWS

Bylaw From Council
 Council of 1092 as per Online /
 Current Information, BC Reg. 711

JD
 ----- B.C.L.S.
 December 7, 1987.

FILED VAVAS2055 182418 2003-10-16-11-54-16-480949

Search ALTOS2 or BC OnLine for Current Information. BC Reg. 76/95

PHASE I

STRATA PLAN VR 2055



LINDA J. O'SHEA, Registrar
Vancouver/New Westminster Land Title Districts

DEALINGS AFFECTING THE COMMON PROPERTY

FILING		DOCUMENT	
NUMBER	DATE	DATE	NATURE AND PARTICULARS
			NOTICE UNDER HIGHWAY (NOTICES) REGULATION, SEE D.F.A. 1217
			THIS LAND MAY BE SUBJECT TO SECTIONS 14 TO 22 OF THE RESORT MUNICIPALITY OF WHISTLER ACT AND THE BYLAWS OF THE WHISTLER RESORT ASSOCIATION FILED UNDER THE SOCIETIES ACT, SEE D.F. 687899
			SUBJECT TO PROVISIONS, SEE CROWN GRANT 642981 L
			HERETO IS ANNEXED EASEMENT RIGHTS OVER PART OF LOT B PLAN 215X IN EXPLANATORY PLAN 18725
R31645	08/04/1987		COVENANT IN FAVOR OF RESORT MUNICIPALITY OF WHISTLER SEC 215 L.T.A. INTER ALIA
R31646	08/04/1987		COVENANT IN FAVOR OF RESORT MUNICIPALITY OF WHISTLER SEC 215 L.T.A. INTER ALIA
R41366	01/05/1987		OPTION TO PURCHASE IN FAVOR OF WHISTLER MOUNTAIN SKI CORPORATION (LINK NO. 221462), INTER ALIA
			Cancelled BG 426567 26.11.93 @ 11:40 L.J. O'Shea R
R-41367	01/05/1987		RIGHT OF FIRST REFUSAL IN FAVOR OF WHISTLER MOUNTAIN SKI CORPORATION (LINK NO. 221462), INTER ALIA.
			Cancelled BG 426568 26.11.93 @ 11:40 L.J. O'Shea R



B.C.L.S.

December 7, 1987.

Common Property Sheet Closed

STRATA PLAN VR 2055

Search ALTOS2 or BC OnLine for Current Information. BC Reg. 78495

PHASE I

DEALINGS AFFECTING THE COMMON PROPERTY

Linda J. O'Shea

LINDA J. O'SHEA
Vancouver / New Westminster

REGISTRATION		DOCUMENTS	
REGISTER	DATE	DATE	NATURE AND PARTICULARS
R 41366	01/05/1987		MORTGAGE IN FAVOR OF THE TORONTO-DOMINION BANK INTER ALIA
R 41366 CANCELLED	GB 12057	8/2/88	K.D. JACQUES / CM
R102308	01/10/1987		MORTGAGE IN FAVOR OF THE TORONTO-DOMINION BANK INTER ALIA
R102308 CANCELLED	GC14392	02/02/89	L.J. O'SHEA / ND
R118819	19/11/1987		STATUTORY RIGHT OF WAY IN FAVOR OF BRITISH COLUMBIA HYDRO AND POWER AUTHORITY WITH PRIORITY OVER R41366, R102308, R41366 AND R41367 INTER ALIA
R118822	19/11/1987		COVENANT IN FAVOR OF REVOLET MUNICIPALITY OF WHISTLER PART IN EXPLANATORY PLAN 18722 SER 215 L.T.A. WITH PRIORITY OVER R41366 AND R102308
HERETO IS ANNEXED EASEMENT GB 1858 OVER PORTIONS OF STRATA LOTS 2, 3, 4, 5 AND 6 STRATA PLAN VR 2049 AS SHOWN ON EXPLANATORY PLAN 1879B			
GB 5575	21/1/88		RESTRICTIVE COVENANT, PART IN EXPLANATORY PLAN 18802 APPURTENANT TO BLOCK A DISTRICT LOT 5316
GB 194536	May 26/92		Change of Bylaws

